

Panasonic[®]

Installation Guide

Included Installation Instructions

Network Camera

Model No. **WV-SC588**

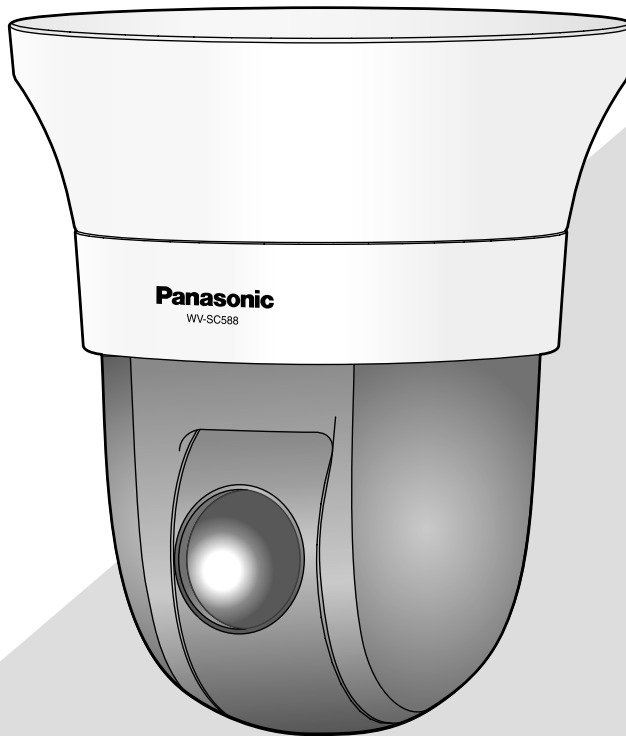

Before attempting to connect or operate this product,
please read these instructions carefully and save this manual for future use.



The model number is abbreviated in some descriptions in this manual.

For Europe

We declare under our sole responsibility that the product to which this declaration relates is in conformity with the standard or other normative document following the provisions of Directive 2004/108/EC.

Wir erklären in alleiniger Verantwortung, daß das Produkt, auf das sich diese Erklärung bezieht, mit der folgenden Norm oder normativen Dokument übereinstimmt. Gemäß den Bestimmungen der Richtlinie 2004/108/EC.

Nous déclarons sous notre propre responsabilité que le produit auquel se réfère la présente déclaration est conforme à la norme spécifiée ou à tout autre document normatif conformément aux dispositions de la directive 2004/108/CE.

Nosotros declaramos bajo nuestra única responsabilidad que el producto a que hace referencia esta declaración está conforme con la norma u otro documento normativo siguiendo las estipulaciones de la directiva 2004/108/CE.

Noi dichiariamo sotto nostra esclusiva responsabilità che il prodotto a cui si riferisce la presente dichiarazione risulta conforme al seguente standard o altro documento normativo conforme alle disposizioni della direttiva 2004/108/CE.

Wij verklaren als enige aansprakelijke, dat het product waarop deze verklaring betrekking heeft, voldoet aan de volgende norm of ander normatief document, overeenkomstig de bepalingen van Richtlijn 2004/108/EC.

Vi erklærer os eneansvarlige for, at dette produkt, som denne deklaration omhandler, er i overensstemmelse med standard eller andre normative dokumenter i følge bestemmelserne i direktiv 2004/108/EC.

Vi deklarerar härmed vårt fulla ansvar för att den produkt till vilken denna deklaration hänvisar är i överensstämmelse med standarddokument eller annat normativt dokument som framställs i direktiv 2004/108/EC.

Ilmoitamme yksinomaisella vastuullamme, että tuote, jota tämä ilmoitus koskee, noudattaa seuraavaa standardia tai muuta ohjeellista asiakirjaa, jotka noudattavat direktiivin 2004/108/EC sääöksiä.

Vi erklærer oss alene ansvarlige for at produktet som denne erklæringen gjelder for, er i overensstemmelse med følgende norm eller andre normgivende dokumenter som følger bestemmelsene i direktiv 2004/108/EC.

WARNING:

- To prevent injury, this apparatus must be securely attached to the wall/ceiling in accordance with the installation instructions.
- To prevent fire or electric shock hazard, do not expose this apparatus to rain or moisture.
- The apparatus should not be exposed to dripping or splashing.
- All work related to the installation of this product should be made by qualified service personnel or system installers.
- The installation shall be carried out in accordance with all applicable installation rules.
- The connections should comply with local electrical code.

CAUTION:

- Any changes or modifications not expressly approved by the party responsible for compliance could void the user's authority to operate the equipment.

For U.S.A

This product contains CR Coin Cell Lithium Battery which contains Perchlorate Material - special handling may apply. See www.dtsc.ca.gov/hazardouswaste/perchlorate/

For U.S. and Canada (UL Listed model):
WV-SC588
For Europe and other countries:
WV-SC588

For Canada

CAN ICES-3(A)/NMB-3(A)

For U.S.A

NOTE: This equipment has been tested and found to comply with the limits for a Class A digital device, pursuant to Part 15 of the FCC Rules. These limits are designed to provide reasonable protection against harmful interference when the equipment is operated in a commercial environment. This equipment generates, uses, and can radiate radio frequency energy and, if not installed and used in accordance with the instruction manual, may cause harmful interference to radio communications. Operation of this equipment in a residential area is likely to cause harmful interference in which case the user will be required to correct the interference at his own expense.

FCC Caution: To assure continued compliance, (example - use only shielded interface cables when connecting to computer or peripheral devices). Any changes or modifications not expressly approved by the party responsible for compliance could void the user's authority to operate this equipment.

For U.S.A

The model number and serial number of this product may be found on the surface of the unit. You should note the model number and serial number of this unit in the space provided and retain this book as a permanent record of your purchase to aid identification in the event of theft.

Model No. _____
Serial No. _____

Contents

Important safety instructions.....	4
Limitation of liability.....	5
Disclaimer of warranty.....	5
Preface	5
Main functions.....	6
About the user manuals	6
System requirements for a PC	7
Trademarks and registered trademarks.....	8
Copyright.....	8
Network security	8
Precautions	9
Precautions for installation.....	12
Major operating controls	14
Insert/remove an SD memory card*	16
Installations/Connections.....	17
Detach the camera	25
Configure the network settings	26
Troubleshooting.....	28
Specifications.....	31
Standard accessories.....	34
Optional accessories.....	34

* SDXC/SDHC/SD memory card is described as SD memory card.

Important safety instructions

- 1) Read these instructions.
- 2) Keep these instructions.
- 3) Heed all warnings.
- 4) Follow all instructions.
- 5) Do not use this apparatus near water.
- 6) Clean only with dry cloth.
- 7) Do not block any ventilation openings. Install in accordance with the manufacturer's instructions.
- 8) Do not install near any heat sources such as radiators, heat registers, stoves, or other apparatus (including amplifiers) that produce heat.
- 9) Only use attachments/accessories specified by the manufacturer.
- 10) Use only with the cart, stand, tripod, bracket, or table specified by the manufacturer, or sold with the apparatus. When a cart is used, use caution when moving the cart/apparatus combination to avoid injury from tip-over.



- 11) Unplug this apparatus during lightning storms or when unused for long periods of time.
- 12) Refer all servicing to qualified service personnel. Servicing is required when the apparatus has been damaged in any way, such as power-supply cord or plug is damaged, liquid has been spilled or objects have fallen into the apparatus, the apparatus has been exposed to rain or moisture, does not operate normally, or has been dropped.

Limitation of liability

THIS PUBLICATION IS PROVIDED "AS IS" WITHOUT WARRANTY OF ANY KIND, EITHER EXPRESS OR IMPLIED, INCLUDING BUT NOT LIMITED TO, THE IMPLIED WARRANTIES OF MERCHANTABILITY, FITNESS FOR ANY PARTICULAR PURPOSE, OR NON-INFRINGEMENT OF THE THIRD PARTY'S RIGHT.

THIS PUBLICATION COULD INCLUDE TECHNICAL INACCURACIES OR TYPOGRAPHICAL ERRORS. CHANGES ARE ADDED TO THE INFORMATION HEREIN, AT ANY TIME, FOR THE IMPROVEMENTS OF THIS PUBLICATION AND/OR THE CORRESPONDING PRODUCT (S).

Disclaimer of warranty

IN NO EVENT SHALL Panasonic System Networks Co., Ltd. BE LIABLE TO ANY PARTY OR ANY PERSON, EXCEPT FOR REPLACEMENT OR REASONABLE MAINTENANCE OF THE PRODUCT, FOR THE CASES, INCLUDING BUT NOT LIMITED TO BELOW:

- (1) ANY DAMAGE AND LOSS, INCLUDING WITHOUT LIMITATION, DIRECT OR INDIRECT, SPECIAL, CONSEQUENTIAL OR EXEMPLARY, ARISING OUT OF OR RELATING TO THE PRODUCT;
- (2) PERSONAL INJURY OR ANY DAMAGE CAUSED BY INAPPROPRIATE USE OR NEGLIGENT OPERATION OF THE USER;
- (3) ALL MALFUNCTIONS OR TROUBLES FROM UNAUTHORIZED DISASSEMBLE, REPAIR OR MODIFICATION OF THE PRODUCT BY THE USER, REGARDLESS OF THE CAUSE OF THE MALFUNCTION OR TROUBLE;
- (4) INCONVENIENCE OR ANY LOSS ARISING WHEN IMAGES ARE NOT DISPLAYED, DUE TO ANY REASON OR CAUSE INCLUDING ANY FAILURE OR PROBLEM OF THE PRODUCT;
- (5) ANY PROBLEM, CONSEQUENTIAL INCONVENIENCE, OR LOSS OR DAMAGE, ARISING OUT OF THE SYSTEM COMBINED BY THE DEVICES OF THIRD PARTY;
- (6) ANY CLAIM OR ACTION FOR DAMAGES, BROUGHT BY ANY PERSON OR ORGANIZATION BEING A PHOTOGENIC SUBJECT, DUE TO VIOLATION OF PRIVACY WITH THE RESULT OF THAT SURVEILLANCE-CAMERA'S PICTURE, INCLUDING SAVED DATA, FOR SOME REASON, BECOMES PUBLIC OR IS USED FOR ANY PURPOSE;
- (7) LOSS OF REGISTERED DATA CAUSED BY ANY FAILURE.

Preface

The network cameras WV-SC588 is designed to operate using a PC on a network (10BASE-T/100BASE-TX).

By connecting to a network (LAN) or the Internet, images and audio from the camera can be monitored on a PC via a network.

Note:

- It is necessary to configure the network settings of the PC and its network environment to monitor images from the camera on the PC. It is also necessary to install a web browser on the PC.
-

Main functions

H.264 dual stream and JPEG (MJPEG) triple encoding at 1920x1080/30 fps

H.264 dual stream output and JPEG (MJPEG) output can be simultaneously provided.

* H.264 stream1: 1920x1080/ max. 30 fps

H.264 stream2: 640x360/ max. 30 fps

Super Dynamic (MEGA Super Dynamic)

(☞ Operating Instructions (included in the CD-ROM))

MEGA Super Dynamic compensates brightness on a pixel-to-pixel basis so that it produces clearer images even if objects have various illumination intensities.

Black & white function

Images will be displayed clear even at night since the camera will be automatically switched from the color mode to the black and white mode under low illumination condition.

2 megapixel lens with 30x optical zoom and high accuracy preset position function

A single camera provides wide area monitoring.

The camera can be installed not only on the ceiling but also on the wall

When using an optional mount bracket, embedded installation on a ceiling or mounting on a wall is available.

Power over Ethernet function

When connecting with an IEEE802.3af compliant PoE (Power over Ethernet) device, power will be supplied by simply connecting a LAN cable.

SDXC/SDHC/SD memory card slot equipped

It is possible to save H.264 videos and JPEG images on the SDXC/SDHC/SD memory card manually at an alarm occurrence, during the period of the schedule, or from a web browser. It is also possible to save JPEG images at a network failure occurrence (download is possible).

(Recommended SDXC/SDHC/SD memory cards ☞ page 33)

Auto tracking function with smooth changing between panning, tilting and zoom

It is possible to perform smooth changing between panning, tilting and zoom.

* The accuracy with the auto tracking function depends on the installation location. Make sure that the installation location is appropriate in advance.

About the user manuals

There are 2 sets of operating instructions for the WV-SC588 as follows.

- Installation Guide: Explains how to install and connect devices, as well as how to connect and configure the network.
- Operating Instructions (included in the CD-ROM): Explains how to perform the settings and how to operate this camera.

Adobe® Reader® is required to read these operating instructions on the provided CD-ROM.

When the Adobe Reader is not installed on the PC, download the latest Adobe Reader from the Adobe web site and install it.

English screens are used in these operating instructions.

System requirements for a PC

CPU:	Intel® Core™ 2 Duo 2.4 GHz or faster recommended
Memory:	512 MB or more (A minimum of 1 GB memory is required when using Microsoft® Windows® 8, Microsoft® Windows® 7 or Microsoft® Windows Vista®.)
Network interface:	10BASE-T/100BASE-TX 1 port
Audio interface:	Sound card (when using the audio function)
Monitor:	Image capture size: 1024 x 768 pixels or more Color: 24-bit True color or better
OS:	Microsoft® Windows® 8 Microsoft® Windows® 7 Microsoft® Windows Vista® Microsoft® Windows® XP SP3
Web browser:	Windows® Internet Explorer® 10.0 (32-bit) Windows® Internet Explorer® 9.0 (32-bit) Windows® Internet Explorer® 8.0 (32-bit) Windows® Internet Explorer® 7.0 (32-bit)
Others:	CD-ROM drive (It is necessary to read the operating instructions and use the software on the provided CD-ROM.) DirectX® 9.0c or later Adobe® Reader® (It is necessary to view the PDF file on the provided CD-ROM.)

IMPORTANT:

- When using a PC that does not meet the above requirements, displaying of images may become slower or the web browser may become inoperable.
- Audio may not be heard if a sound card is not installed on a PC. Audio may be interrupted depending on the network environment.
- Microsoft Windows RT, Microsoft Windows 7 Starter, Microsoft Windows Vista Starter and Microsoft Windows XP Professional 64-bit Edition are not supported.
- When using Windows 8, use it in the desktop. The software cannot be used in the Modern UI design.
- When using IPv6 for communication, use Microsoft Windows 8, Microsoft Windows 7 or Microsoft Windows Vista.

Note:

- For further information about PC system requirements and precautions for when using Microsoft Windows 8, Microsoft Windows 7, Microsoft Windows Vista, or Windows Internet Explorer, click "Manual" - "Open" from the supplied CD-ROM and refer to "Notes on Windows® / Internet Explorer® versions".
 - If using Microsoft Windows XP, screen tearing* may occur when the shooting scene drastically changes (for example, while shooting fast-moving subjects or while controlling panning/tilting) due to the GDI restrictions of the OS.
* A phenomenon in which portions of the screen are displayed out of alignment
 - For information on the operation verification of the supported operating systems and web browsers, refer to our web-site at <http://security.panasonic.com/pss/security/support/index.html>.
-

Trademarks and registered trademarks

- Microsoft, Windows, Windows Vista, Internet Explorer, and DirectX are either registered trademarks or trademarks of Microsoft Corporation in the United States and/or other countries.
- Microsoft product screen shot(s) reprinted with permission from Microsoft Corporation.
- Intel and Intel Core are trademarks of Intel Corporation in the U.S. and other countries.
- Adobe, Acrobat Reader, and Reader are either registered trademarks or trademarks of Adobe Systems Incorporated in the United States and/or other countries.
- SDXC Logo is a trademark of SD-3C, LLC.
- iPad, iPhone, and iPod touch are trademarks of Apple Inc., registered in the U.S. and other countries.
- Android is a trademark of Google Inc.
- All other trademarks identified herein are the property of their respective owners.

Copyright

Distributing, copying, disassembling, reverse compiling and reverse engineering of the software provided with this product are all expressly prohibited. In addition, exporting any software provided with this product violating export laws is prohibited.

Network security

As you will use this unit connected to a network, your attention is called to the following security risks.

- ① Leakage or theft of information through this unit
- ② Use of this unit for illegal operations by persons with malicious intent
- ③ Interference with or stoppage of this unit by persons with malicious intent

It is your responsibility to take precautions such as those described below to protect yourself against the above network security risks.

- Use this unit in a network secured by a firewall, etc.
- If this unit is connected to a network that includes PCs, make sure that the system is not infected by computer viruses or other malicious entities (using a regularly updated anti-virus program, anti-spyware program, etc.).
- Protect your network against unauthorized access by restricting users to those who log in with an authorized user name and password.
- Apply measures such as user authentication to protect your network against leakage or theft of information, including image data, authentication information (user names and passwords), alarm mail information, FTP server information and DDNS server information.
- After the unit is accessed by the administrator, make sure to close the browser.
- Change the administrator password periodically.
- Do not install the camera in locations where the camera or the cables can be destroyed or damaged by persons with malicious intent.

Precautions

Refer installation work to the dealer.

Installation work requires technique and experience. Failure to observe this may cause fire, electric shock, injury, or damage to the product.

Be sure to consult the dealer.

Stop the operation immediately when something is wrong with this product.

When smoke goes up from the product, the smell of smoke comes from the product, or the exterior of the product has deteriorated, continued use will cause a fire or fall of the product resulting in injury, or damage to the product.

In this case, turn the power off immediately and contact qualified service personnel for service.

Do not attempt to disassemble or modify this product.

Failure to observe this may cause fire or electric shock. Consult the dealer for the repair or inspections.

Do not insert any foreign objects.

Fire or electrical shock may be caused if water or any foreign objects, such as metal objects, enter inside the unit. Turn the power off immediately and contact qualified service personnel for service.

Select an installation area that can support the total weight.

Selecting an inappropriate installation surface may cause this product to fall down or topple over, resulting in injury or accidents.

Installation work shall be started after sufficient reinforcement.

Periodic inspections shall be conducted.

Rust on the metal parts or screws may cause a fall of the product resulting in injury or accidents.

Consult the dealer for the inspections.

Do not use this product in an inflammable atmosphere.

Failure to observe this may cause an explosion resulting in injury.

Avoid installing this product in the locations where salt damage occurs or corrosive gas is produced.

Otherwise, the mounting portions will deteriorate and accidents such as a fall of the product may occur.

The measures of protection against a fall of this product shall be taken.

Failure to observe this may cause a drop resulting in injury or accidents.

Be sure to install the safety wire.

The exclusively designed mount bracket shall be used.

Failure to observe this may cause a drop resulting in injury or accidents.

Use the exclusively designed mount bracket for installation.

The screws and bolts must be tightened to the specified torque.

Failure to observe this may cause a drop resulting in injury or accidents.

Do not install this product in locations subject to vibration.

Loosening of mounting screws or bolts may cause a fall of the product resulting in injury or accidents.

Do not strike or give a strong shock to this product.

Failure to observe this may cause fire or injury.

Turn the power off when do wiring of this product.

Failure to observe this may cause electric shock. In addition, short circuit or wrong wiring may cause fire.

Do not rub the edges of metal parts with your hand.

Failure to observe this may cause injury.

Do not touch the main body while this product is panning/tilting.

Fingers may be caught up in the moving part, and that may result in injury.

Keep SDXC/SDHC/SD memory cards away from infants and children.

Otherwise, they may swallow the cards by mistake. In this case, consult a doctor immediately.

Do not install or clean the camera, or touch this product, the power cable or the connected cables during thunder storms.

Failure to observe this may cause electric shock.

Install this product in a location high enough to avoid people and objects from bumping the product.

Failure to observe this may cause injury.

Do not hang down from this product or use this product as a pedestal.

Failure to observe this may cause a drop resulting in accidents.

Do not damage the power cable.

Do not damage, fabricate, twist, stretch, bundle, or forcibly bend the power cable. Do not place heavy objects on it, and keep it away from heat sources.

Use of a damaged power cable may cause electric shock, short circuit, or fire.

Consult the dealer for repair.

Correctly perform all wiring

Short circuits in the wiring or incorrect wiring may cause fire or electrical shock.

Turn the power off when cleaning this product.

Failure to observe this may cause injury.

[Precautions for use]**This product is designed to be used indoors. This product is not operable outdoors.****This product has no power switch.**

When turning off the power, disconnect the power supply from the 12 V DC power supply or the PoE device.

To keep on using with stable performance

Do not use this product in hot and humid conditions for a long time. Failure to observe this causes component degradation resulting in life shortening of this product. Do not expose this product to direct heat sources such as a heater.

Handle this product with care.

Do not drop this product, nor apply shock or vibration to the product. Failure to observe this may cause trouble.

About the PC monitor

When displaying the same image on the monitor for a long time, the monitor may be damaged.

It is recommended to use a screen-saver.

When an error is detected, this product will restart automatically.

This product will be inoperable for around 2 minutes after the restart just as when the power is turned on.

Product disposal/transfer

Data saved on this product or a storage device used with this product may lead to personal information leakage. When it is necessary to dispose or give this product to someone, even when for repair, make sure that there is no data on this product.

Do not hold the dome section.

The dome section of this unit rotates 360°. When removing this unit from a ceiling or wall, turn the unit while holding the fixed section.

Cleaning this product body

Be sure to turn off the power before cleaning. Failure to observe this may cause injury. Do not use strong abrasive detergent when cleaning this product. Otherwise, it may cause discoloration. When using a chemical cloth for cleaning, read the caution provided with the chemical cloth product.

IMPORTANT:

- The camera position may be moved inadvertently while cleaning the camera body. Restart the camera or refresh the camera position (position refresh) to correct the camera position. Refer to the Operating Instructions on the provided CD-ROM for further information.
-

Make sure that the product does not become wet.

Keep this camera away from water and moisture.

Transmission interval

Image transmission interval may become slow depending on the network environment, PC performance, shooting subject, access number, etc.

About SD memory card

- Before removing the SD memory card, make sure to select "Not use" for "SD memory card" on the [SD memory card] tab of "Basic" page on the setup menu first. (Refer to Operating Instructions (included in the CD-ROM)) Refer to page 16 for descriptions of how to insert/remove an SD memory card.
- When using an SD memory card, format it using this product. Recorded data on the SD memory card will be deleted when formatted. If an unformatted SD memory card or an SD memory card formatted with other devices is used, this product may not work properly or performance deterioration may be caused. Refer to the Operating Instructions on the provided CD-ROM for how to format an SD memory card.
- When some SD memory cards are used with this product, the product may not work properly or performance deterioration may be caused. Use the SD memory cards recommended in page 33.

Code label

The code labels (accessory) are required at inquiry for trouble. Use caution not to lose these labels. It is recommended to paste one of the labels onto the CD-ROM case.

About the MOS image sensor

- When continuously shooting a bright light source such as a spotlight, the color filter of the MOS image sensor may become deteriorated and this may cause discoloration. Even when changing the fixed shooting direction after continuously shooting a spotlight for a certain period, the discoloration may remain.
- When shooting fast-moving subjects or performing panning/tilting operations, objects crossing the shooting area may look to be bending askew.

Periodically images on the screen appear to be distorted

When the camera is installed in a location where it is subject to small vibrations (for example, when it is installed near devices that vibrate), images may appear distorted and stretched lengthways. This phenomenon is a characteristic of image pickup devices that use CMOS sensors and is caused by the relationship between the periodic movements of the camera and the timing that the image sensor reads images. This is not a problem with the camera. To reduce the possibility of this phenomenon occurring, install the camera in a secure location.

AVC Patent Portfolio License

THIS PRODUCT IS LICENSED UNDER THE AVC PATENT PORTFOLIO LICENSE FOR THE PERSONAL USE OF A CONSUMER OR OTHER USES IN WHICH IT DOES NOT RECEIVE REMUNERATION TO (i) ENCODE VIDEO IN COMPLIANCE WITH THE AVC STANDARD (“AVC VIDEO”) AND/OR (ii) DECODE AVC VIDEO THAT WAS ENCODED BY A CONSUMER ENGAGED IN A PERSONAL ACTIVITY AND/OR WAS OBTAINED FROM A VIDEO PROVIDER LICENSED TO PROVIDE AVC VIDEO. NO LICENSE IS GRANTED OR SHALL BE IMPLIED FOR ANY OTHER USE. ADDITIONAL INFORMATION MAY BE OBTAINED FROM MPEG LA, L.L.C. SEE [HTTP://WWW.MPEGLA.COM](http://www.mpegla.com)

Consumable parts

The following are consumables: Replace them in accordance with their operating lifetimes. Their operating lifetimes vary depending on the usage environment and conditions. The operating lifetimes below are just guides for when using the camera at +35 °C {95 °F}.

- Lens unit, panning motor, tilting motor, flat cable for tilting, Slip ring:
Approx. 3.7 million operations (Approx. 20000 hours)

About the automatic status detection function

When this product malfunctions due to exogenous noise, etc. for 30 seconds or more, the product will automatically reset and will return to normal state. When the product is reset, initialization will be carried out as when the power of the product is turned on. When the product repeatedly resets, exogenous noise level around the product may be high and that may cause malfunction. Contact your dealer for instructions.

Motor operating sound

The operating sound may be louder depending on the speed of panning/tilting operations. When you feel uneasy, the operating sound can be diminished by reducing the setting value of auto panning speed.

Lens and pan/tilt head

If a lens and pan/tilt head are not performed for a long period of time, the grease coating inside these parts may become sticky. That may obstruct the parts from moving. To prevent this, move the lens or pan/tilt head periodically. Or perform position refresh.

Position refresh

During the use for a long period of time, the preset positions may become inaccurate. When “Position refresh” is set for the created schedule, the camera position will be corrected periodically.

Refer to the Operating Instructions on the provided CD-ROM for how to perform the settings.

Equipment classification and power source indication label

Refer to the indication label on the bottom side of this unit for the equipment classification, power source, and other information.

Precautions for installation

Panasonic assumes no responsibility for injuries or property damage resulting from failures arising out of improper installation or operation inconsistent with this documentation.

This camera is designed to be used indoors.

This product is not operable outdoors.

Do not expose this camera to direct sunlight for hours and do not install the product near a heater or an air conditioner. Otherwise, it may cause deformation, discoloration and malfunction. Keep this camera away from water and moisture.

Power supply

This product has no power switch.

When turning off the power, turn off a power supply or remove a power cable. When the power cable of the product is connected to the power supply device, the power will be supplied to the product. When the product is supplied, the product will perform panning, tilting, zooming and focusing.

Before cleaning the product, make sure that the power cable is not connected to the main power supply.

Installation area for this product

Select an appropriate place for the installation area (such as a strong wall or ceiling) in your particular environment.

- When the installation area is not strong enough, reinforce and strengthen it or use an optional mount bracket (WV-Q105 or WV-Q126A).
- When the product is installed on a wall, use the wall mount bracket (WV-Q119).
- Do not mount the product on a plaster board or a wooden section because they are too weak. If the product is unavoidably mounted on such a section, the section shall be sufficiently reinforced.

Do not place this product in the following places:

- Locations where it may get wet from rain or water splash (including under the eaves, etc.)
- Locations where a chemical agent is used such as a swimming pool
- Locations subject to moisture or oil smoke such as a kitchen
- Locations that have a specific environment that is subject to an inflammable atmosphere or solvents
- Locations where a radiation, an X-ray, a strong radio wave or a strong magnetic field is generated
- Locations where corrosive gas is produced, locations where it may be damaged by briny air such as seashores
- Locations where the temperature is not within the specified range (☞ page 31)
- Locations subject to vibrations, such as on vehicles, marine vessels, or above product lines (This product is not designed for on-vehicle use.)
- Locations subject to condensation as the result of severe changes in temperature

Mounting method for this product

This product is designed to be used as a pendant mount camera. If the product is mounted on a desktop or at a slant, it may not work correctly and its lifetime may be shortened.

Procure fixing screws separately.

The screws that mount the camera mount bracket (accessory) and other brackets on a ceiling or a wall are not supplied. Prepare them according to the material and strength of the area where the product is to be installed.

<Installing the unit directly on a ceiling using the camera mount bracket (accessory)>

- Required screws: M4 (4 pcs.)
- Minimum pull-out strength: 196 N {44 lbf} (per 1 pc.)

Screw tightening

- The screws and bolts must be tightened with an appropriate tightening torque according to the material and strength of the installation area.
- Do not use an impact driver. Use of an impact driver may damage the screws or cause tightening excessively.
- When a screw is tightened, make the screw at a right angle to the surface. After tightening the screws or bolts, perform checks to ensure that the tightening is sufficient enough so that there is no movement or looseness.

Make sure to remove this product if it will no longer be used.

Radio disturbance

When this product is used near TV/radio antenna, strong electric field or magnetic field (near a motor, a transformer or a power line), images may be distorted and noise may be produced.

PoE (Power over Ethernet)

Use a PoE hub/device that is compliant with IEEE802.3af standard.

Router

When connecting this product to the Internet, use a broadband router with the port forwarding function (NAT, IP masquerade).

Refer to the Operating Instructions on the provided CD-ROM for further information about the port forwarding function.

Check before installation

Compatibility of devices is restricted. Before installation, check the ratings and dimensions of the devices to be used.

Contact your dealer for details.

Time & date setting

It is necessary to set the time & date before putting this product into operation. Refer to the Operating Instructions on the provided CD-ROM for descriptions of how to perform the settings.

Protective caps

The protective caps are used to prevent dirt and dust from entering inside this product. Keep the protective caps inserted in connectors that are not used.

Major operating controls

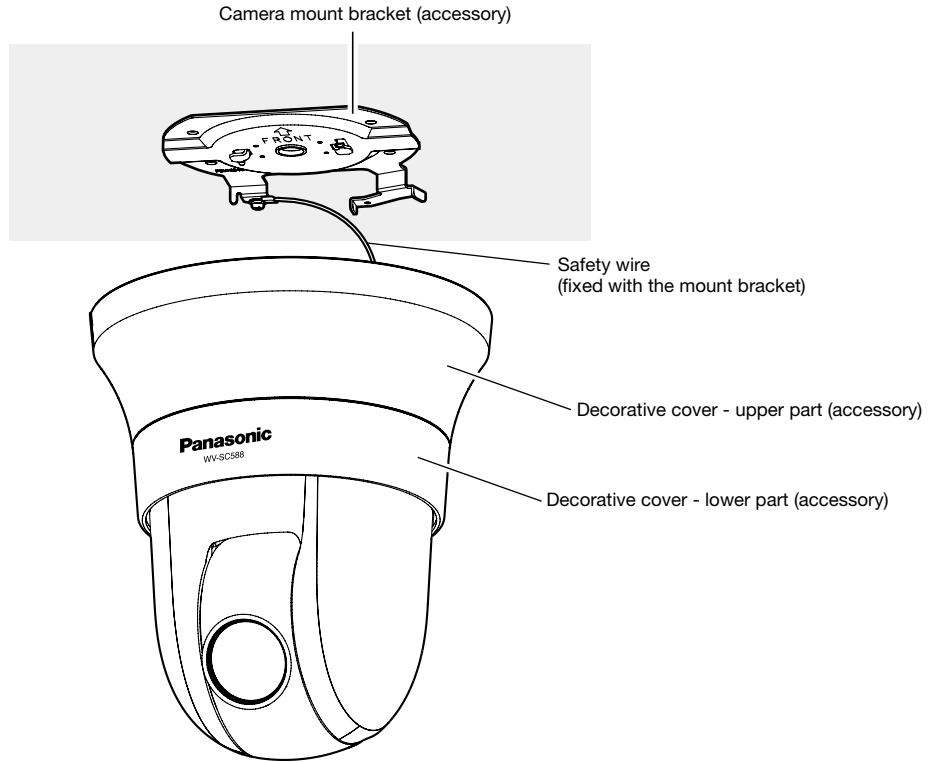

<Front view>

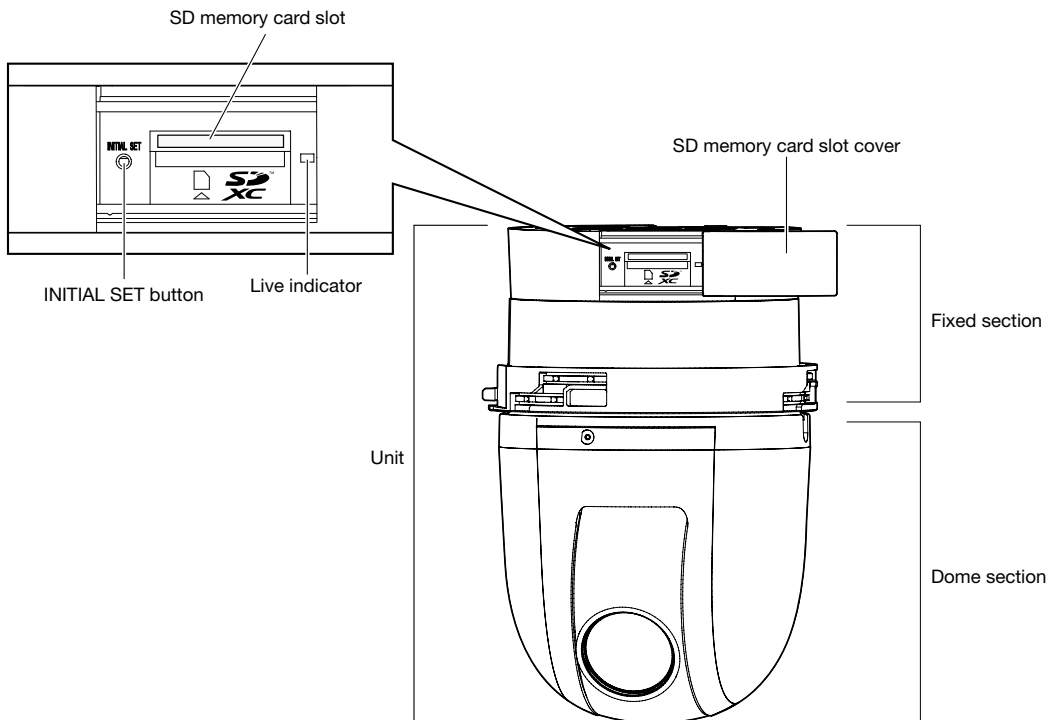

<Rear view>

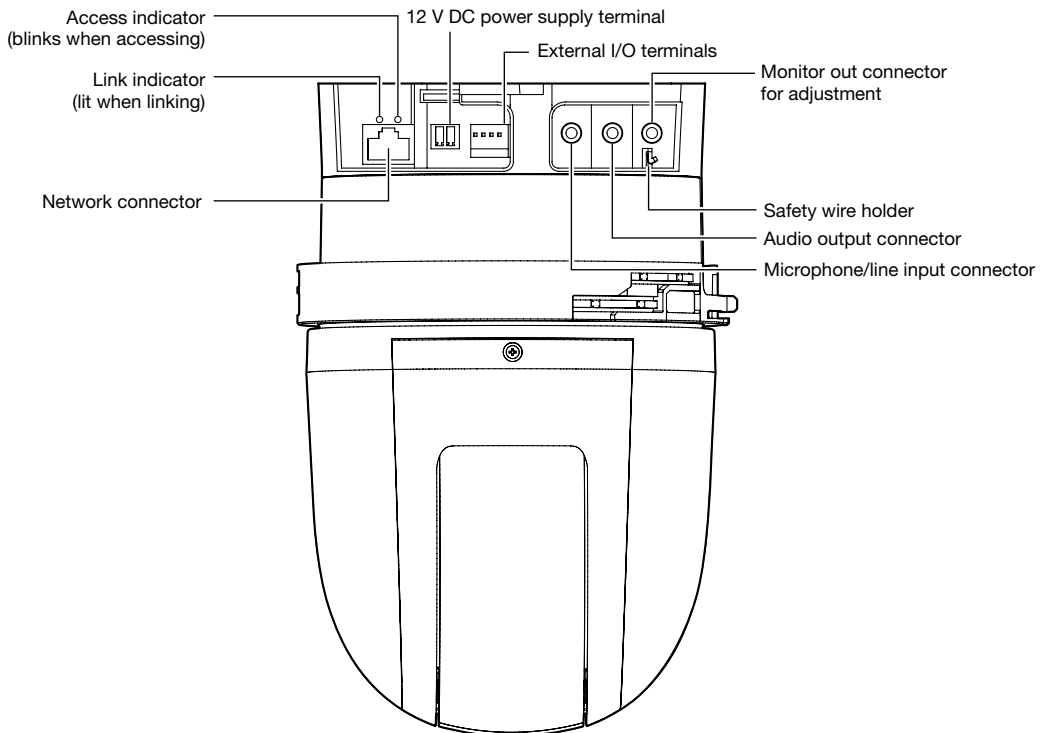

• Monitor out connector for adjustment

The video output is set to NTSC in the default settings of the camera. If you want to change the video output setting to PAL, refer to the Operating Instructions on the provided CD-ROM.

• How to initialize the camera

IMPORTANT:

- When the camera is initialized, the settings including the network settings will be initialized. Note that the preset position settings and the CRT key (SSL encryption key) used for the HTTPS protocol will not be initialized.
- Before initializing the settings, it is recommended to write down the settings in advance.
- Do not turn off the power of the camera during the process of initialization. Otherwise, it may fail to initialize and may cause malfunction.

Step 1

Turn off the power of the camera. When using a PoE hub, disconnect the LAN cable from the camera. When using an external power supply, disconnect the power cable plug from the 12 V DC power supply terminal.

Step 2

Slide the SD memory card slot cover and check the position of the INITIAL SET button.

Step 3

Turn on the power of the camera while holding down the INITIAL SET button, and then keep holding down the button for around 5 seconds. The camera will start up and the settings including the network settings will be initialized.

Step 4

The live indicator will light orange → light off → blink orange → light orange. It takes about 2 minutes for the initialization to complete (when not connected to a network).

(About the live indicator  page 30)

Insert/remove an SD memory card

How to insert an SD memory card

IMPORTANT:

- When inserting an SD memory card, make sure the direction.

Step 1

Slide the SD memory card slot cover to the right to expose the slot.

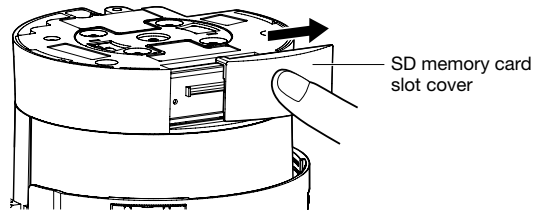

Step 2

Insert an SD memory card fully into the SD memory card slot, and then push the memory card straight into the slot until a click is heard.

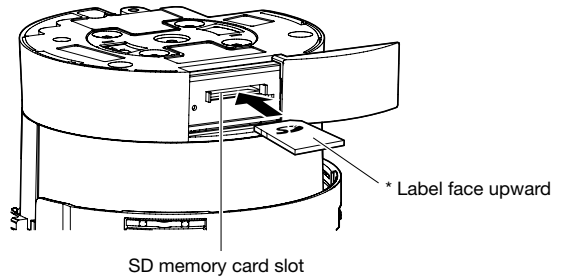

Step 3

Shut the SD memory card slot cover.

How to remove the SD memory card

IMPORTANT:

- Before removing the SD memory card, make sure to select "Not use" for "SD memory card" on the [SD memory card] tab of the "Basic" page on the setup menu first. (See Operating Instructions (included in the CD-ROM))

Step 1

Open the SD memory card slot cover by following steps 1 of the "How to insert an SD memory card" section.

Step 2

Push the SD memory card until a click is heard and then pull the SD memory card from the slot.

Step 3

Shut the SD memory card slot cover.

Installations/Connections

Caution:

- A READILY ACCESSIBLE DISCONNECT DEVICE SHALL BE INCORPORATED TO THE EQUIPMENT POWERED BY 12 V DC POWER SUPPLY.
- FOR UL LISTED MODEL(S), ONLY CONNECT 12 V DC CLASS 2 POWER SUPPLY (UL 1310/CSA 223) or LIMITED POWER SOURCE (IEC/EN/UL/CSA 60950-1).

Before installation, prepare the following

There are 4 methods to install the camera to a ceiling or wall as described below. Prepare the required devices and cables for each installation method before starting the installation.

<Installing the camera to a ceiling that has adequate structural strength>

Use the camera mount bracket (accessory).

- Procure 4 screws (M4) to secure the camera mount bracket (accessory).
- Select screws according to the material of the ceiling that the camera will be mounted to.
- The minimum required pull-out capacity of a single screw is 196 N {44 lbf} or more.
- When mounting the camera on a concrete ceiling, use an AY plug bolt (M4) for securing.
(Recommended tightening torque: 1.6 N·m {1.18 lbf·ft})

<Installing the camera to a ceiling that has inadequate structural strength such as plaster board ceiling>

The area of the ceiling that the camera will be installed to must be sufficiently reinforced, or the optional ceiling mount bracket for the camera (WV-Q105, weight approx. 0.15 kg {0.33 lbs}) must be used.

- When using the ceiling mount bracket (WV-Q105), prepare 2 anchor bolts (M10) to secure the bracket to a roof space (including 1 for securing the safety wire).
- The minimum required pull-out capacity of a single screw or anchor bolt is 5 times or more of the total weight of the camera and all of its parts.
- Existing anchor bolts can be used to secure the safety wire to a ceiling. If existing anchor bolts are used, there may not be enough supplied nuts to be used with all the anchor bolts. In this case, procure the required nuts separately.

<Installing the camera embedded to a ceiling that has inadequate structural strength such as plaster board ceiling>

The area of the ceiling that the camera will be installed to must be sufficiently reinforced, or the optional ceiling embedding bracket for the camera (WV-Q126A, weight approx. 1.2 kg {2.65 lbs}) must be used.

- When using the ceiling embedding bracket (WV-Q126A), prepare 2 anchor bolts (M10) to secure the bracket to a roof space (including 1 for securing the safety wire).
- The minimum required pull-out capacity of a single screw or anchor bolt is 5 times or more of the total weight of the camera and all of its parts.
- Existing anchor bolts can be used to secure the safety wire to a ceiling. If existing anchor bolts are used, there may not be enough supplied nuts to be used with all the anchor bolts. In this case, procure the required nuts separately.

<Installing the camera to a wall>

Use the wall mount bracket (WV-Q119, weight approx. 0.65 kg {1.43 lbs}).

- Procure 4 screws (M4) to secure the wall mount bracket (WV-Q119) to the wall.
- Select screws according to the material of the wall that the camera will be mounted to.
- The minimum required pull-out capacity of a single screw or anchor bolt is 5 times or more of the total weight of the camera and all of its parts.

When installing the camera using the ceiling mount bracket, the ceiling embedding bracket, or the wall mount bracket, refer to the instructions included with those optional accessories.

Examples of when using the optional brackets to install the camera

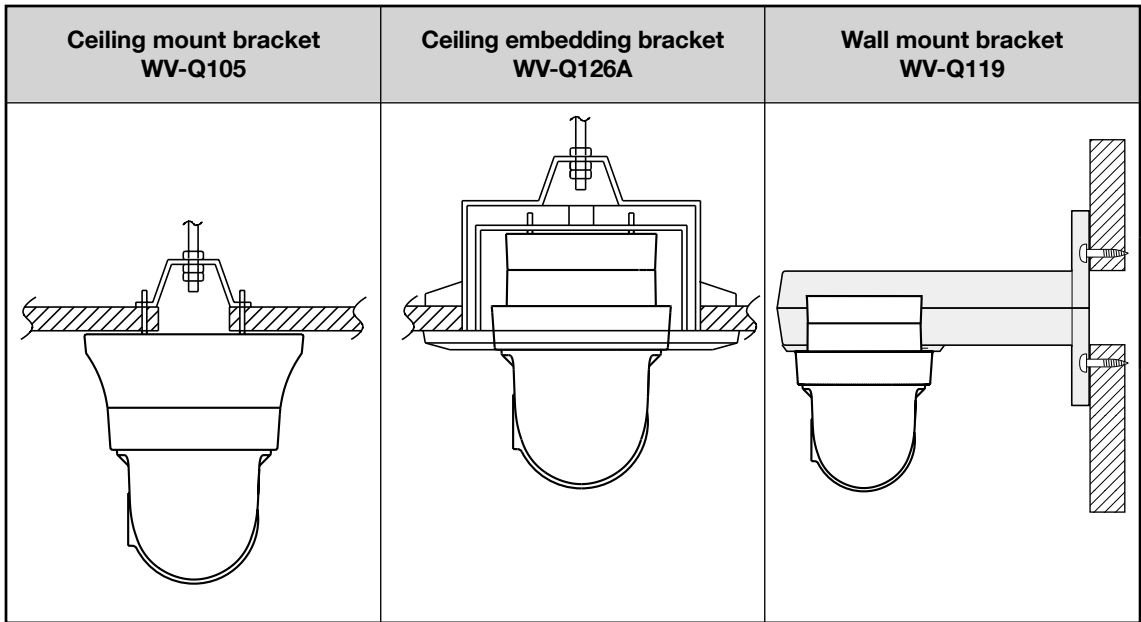

IMPORTANT:

- Before starting the installation/connection, prepare the required devices and cables. Before starting the connection, turn off the power of the devices including the camera and the PC or disconnect from the 12 V DC power supply.
 - Remove the cover film from the lens after the installation is complete.
 - When using 12 V DC power supply, strip 3 mm to 7 mm {1/8 inches to 9/32 inches} from the end of the wire, and twist the stripped part of the wire sufficiently to avoid short circuit, before installing the camera and connecting the cables (see page 22).
 - Be sure to install the safety wire to prevent a fall of the camera resulting in injury or accidents.
-

Installing the camera on a ceiling

The following are descriptions of how to install the camera on a ceiling using the camera mount bracket (accessory). There are 2 methods; wiring through a hole in the ceiling (☞ page 19) and wiring through a cable guide (unnecessary to make a hole in the ceiling) (☞ page 23).

Wire through a hole in the ceiling

Step 1

Fix the camera mount bracket (accessory) with 4 screws (M4, locally procured). There should be no obstacles such as wall in a range of 100 mm {3-15/16 inches} away from the center point of the camera mount bracket.

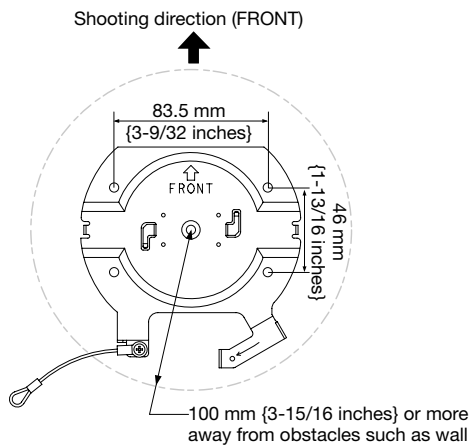

Step 2

Make a hole in the ceiling to pass the cables through. Make a hole 25 mm {31/32 inches} in diameter. The center point of the hole should be located approx. 75 mm {2-15/16 inches} away from the center point of the camera mount bracket.

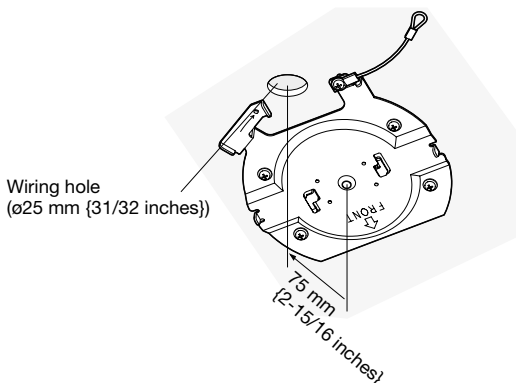

Step 3

When using an SD memory card, insert the SD memory card into the SD memory card slot before mounting the camera to the mount bracket. Refer to page 16 for how to insert the SD memory card.

Step 4

Remove the protective caps from connectors that you intend to use. Keep the removed protective caps for future use.

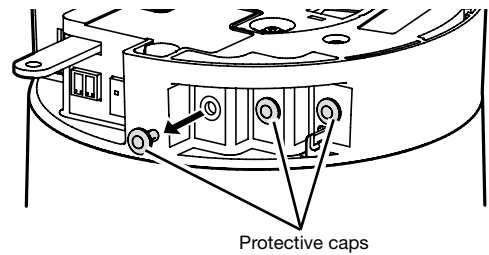

IMPORTANT:

- The protective caps are used to prevent dirt and dust from entering inside this product. Keep the protective caps inserted in connectors that are not used.

Step 5

Attach the safety wire fixed with the camera mount bracket (accessory) to the camera. After attaching the safety wire to the camera, confirm that the ring part at the end of the safety wire is securely hooked on the safety wire holder.

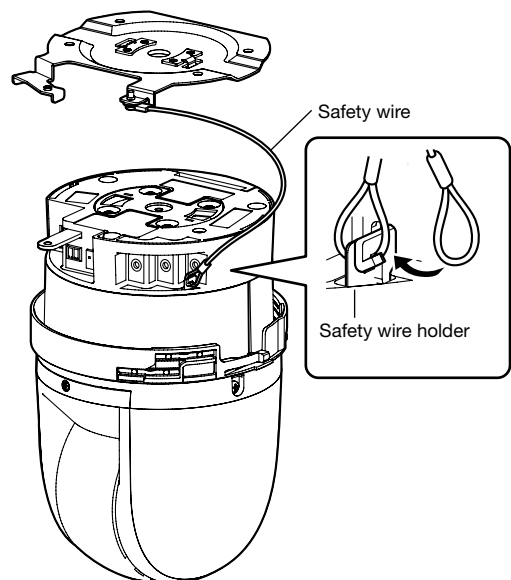

Step 6

Connect cables to the External I/O terminals, microphone/line input connector, audio output connector and the monitor out connector for adjustment. When connecting these cables, hold the main body of the camera.

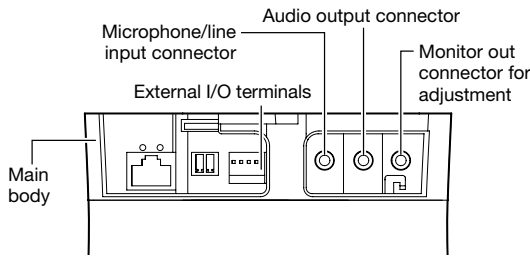

• External I/O terminals

Connect external devices.

When connecting an external device, remove 9 mm - 10 mm {11/32 inches - 13/32 inches} of the outer jacket of the cable and twist the cable core to prevent the short circuit first.

Specification of cable (wire): AWG #22 - #28,

Single core, twisted

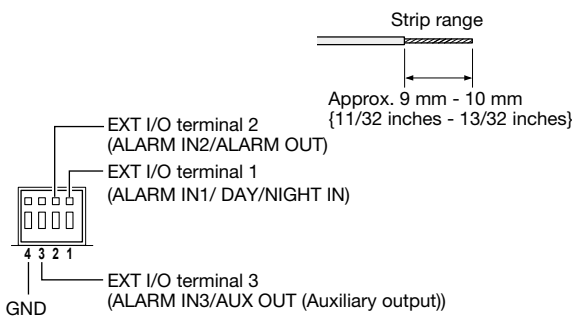

IMPORTANT:

- Do not connect 2 wires or more directly to a terminal. When it is necessary to connect 2 or more wires, use a splitter.
- Off, input, and output of the external I/O terminal 2 and 3 can be switched by configuring the setting. Refer to the Operating Instructions on the provided CD-ROM for further information about the EXT I/O terminal 2 and 3 (ALARM IN2, 3) settings ("Off", "Alarm input", "Alarm output" or "AUX output").
- The default of EXT I/O terminals is "Off". When "Off" is selected, it is possible to connect external devices as well as the input setting.
- When using the EXT I/O terminals as the output terminals, ensure they do not cause signal collision with external signals.

<Ratings>

- ALARM IN1/ DAY/NIGHT IN, ALARM IN2, ALARM IN3
Input specification: No-voltage make contact input (4 V - 5 V DC, internally pulled up)
OFF: Open or 4 V - 5 V DC
ON: Make contact with GND (required drive current: 1 mA or more)

- ALARM OUT, AUX OUT

Output specification: Open collector output (maximum applied voltage: 20 V DC)

Open: 4 V - 5 V DC by internal pull-up

Close: Output voltage 1 V DC or less (maximum drive current: 50 mA)

• Microphone/line input cable

Connect a monaural mini plug (ø3.5 mm).

- Input impedance: Approx. 2 k Ω (unbalanced)
- Recommended cable length: Less than 1 m {3.28 feet} (for microphone input) Less than 10 m {32.8 feet} (for line input)
- Recommended microphone: Plug-in power type (option)
- Supply voltage: 2.5 V \pm 0.5 V
- Recommended sensitivity of microphone: -48 dB \pm 3 dB (0 dB=1 V/Pa, 1 kHz)
- Input level for the line input: Approx. -10 dBV
- Recommended plug: L type

IMPORTANT:

- Connect/disconnect the audio cables and turn on the power of the camera after turning off the power of the audio output devices. Otherwise, loud noise may be heard from the speaker.

• Audio output cable

Connect a stereo mini plug (ø3.5 mm) (Audio output is monaural.). Use an external powered speaker.

- Output impedance: Approx. 600 Ω (unbalanced)
- Recommended cable length: Less than 10 m {32.8 feet}
- Output level: -20 dBV
- Recommended plug: L type (A straight type plug must be 40 mm {1-9/16 inches} or less.)

Note:

- Make sure that the stereo mini plug is connected to this cable. When a monaural mini plug is connected, audio may not be heard. When connecting a monaural speaker with amplifier, use an optional conversion cable (mono-stereo).

• Monitor out connector for adjustment

Connect a monaural mini plug (ø3.5 mm) (only for checking if images are displayed on the monitor).

- Recommended plug: Straight type (Because of the pin array difference, it is difficult to fit an L type plug into this connector.)

IMPORTANT:

- The monitor out connector for adjustment is provided only for checking the adjustment of the angular field of view on the video monitor when installing the camera or when servicing. It is not provided for recording/monitoring use.
- Black bands may appear at the top and bottom or right and left of the screen. (That does not affect the adjustment because the angular field of view is not changed.)

Step 7

Mount the camera onto the camera mount bracket (accessory). Fit the lock plate of the camera onto the guide part of the camera mount bracket, and rotate the camera clockwise after inserting the camera while putting the center of the camera onto the center of the camera mount bracket.

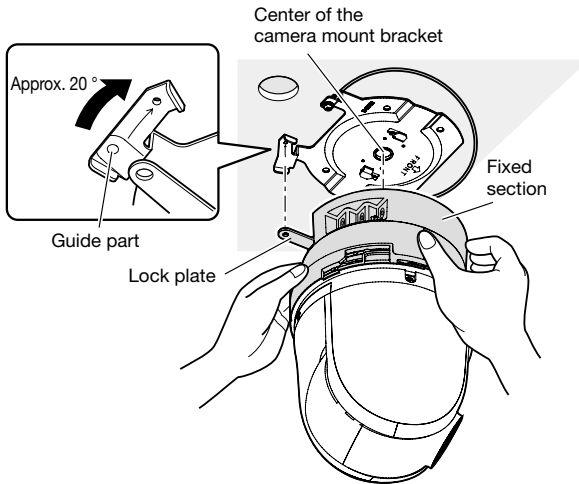

IMPORTANT:

- When mounting the camera onto the camera mount bracket, hold the fixed section of the unit. Mounting the camera while holding the dome section may result in malfunction.

Step 8

Fix the camera on the camera mount bracket (accessory) using the camera fixing screw (M3, accessory). Recommended tightening torque: 0.68 N·m {0.50 lb·ft}

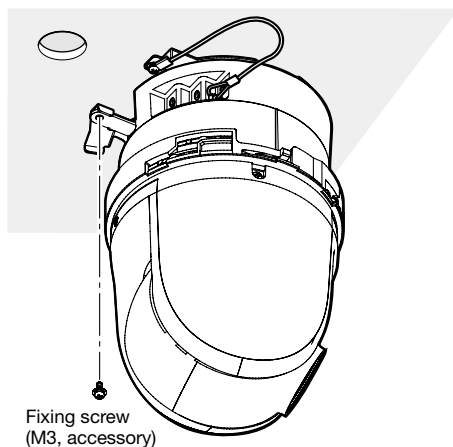

Step 9

Connect a LAN cable and power cable to the camera.

<When using a PoE device>

Connect a LAN cable to the camera.

<When using a 12 V DC power supply>

After connecting a LAN cable to the camera, connect an AC adaptor to the 12 V DC power supply terminal.

IMPORTANT:

- Do not touch the camera in the process of initialization. Otherwise, it may fail to initialize and may cause malfunction.

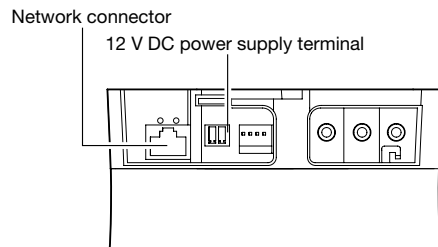

• Network connector

Connect a LAN cable (category 5 or better) to the network connector.

IMPORTANT:

- Use all 4 pairs (8 pins) of the LAN cable.
- The maximum cable length is 100 m {328 feet}.
- Make sure that the PoE device in use is compliant with IEEE802.3af standard.
- When connecting both the 12 V DC power supply and the PoE device for power supply, 12 V DC will be used for power supply. If a 12 V DC power supply and a PoE hub or router are used at the same time, network connections may not be possible. In this case, disable the PoE settings. Refer to the operating instructions of the PoE hub or router in use.
- When the LAN cable is disconnected once, reconnect the cable after around 2 seconds. When the cable is quickly reconnected, the power may not be supplied from the PoE device.
- The network camera is only intended for a connection to an ethernet or PoE network without routing to the outside plant.

• 12 V DC power supply terminal

- ① Loosen the screw of the power cable plug (accessory).
- ② Connect the output cable to the power cable plug.
Strip 3 mm to 7 mm {1/8 inches to 9/32 inches} from the end of the wire, and twist the stripped part of the wire sufficiently to avoid short circuit.
Specification of cable (wire): 16 AWG - 24 AWG,
Single core, twisted
- * Check whether the stripped part of the wire is not exposed and is securely connected.
- ③ Tighten the screw of the power cable plug.
- ④ Connect the power cable plug to the 12 V DC power supply terminal on the rear of the camera.

* FOR UL LISTED MODEL(S), ONLY CONNECT 12 V DC CLASS 2 POWER SUPPLY (UL 1310/CSA 223) or LIMITED POWER SOURCE (IEC/EN/UL/CSA 60950-1).

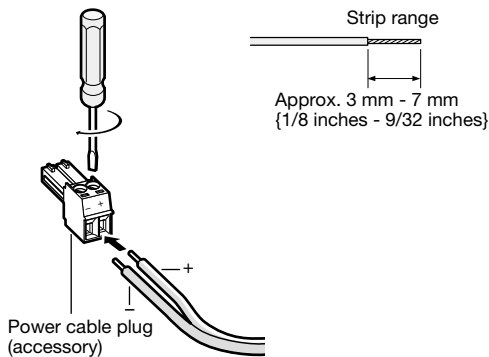

IMPORTANT:

- The 12 V DC power supply shall be insulated from the commercial AC power.
- Be sure to use the power cable plug provided with this product.
- Be sure to fully insert the power cable plug into the 12 V DC power supply terminal. Otherwise, it may damage the camera or cause malfunction.
- Be sure to use an AC adaptor compliant with the Specifications regarding power source and power consumption (page 31).

Step 10

After completing the cable connections, attach the upper and lower parts of the decorative cover (accessory).

- ① Match the "I" position of the decorative cover to the arrow of the unit, and then slightly push up the decorative cover while holding the lower part of the decorative cover.

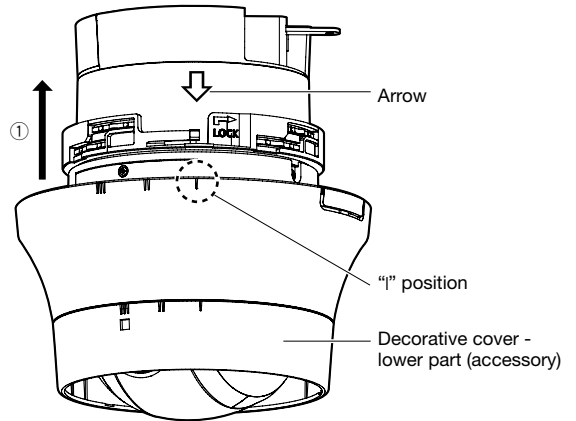

- ② Push the decorative cover up until it is approx. 10 mm {13/32 inches} from the ceiling, and then turn the decorative cover by approx. 16 ° in the direction of the arrow (clockwise) as illustrated.

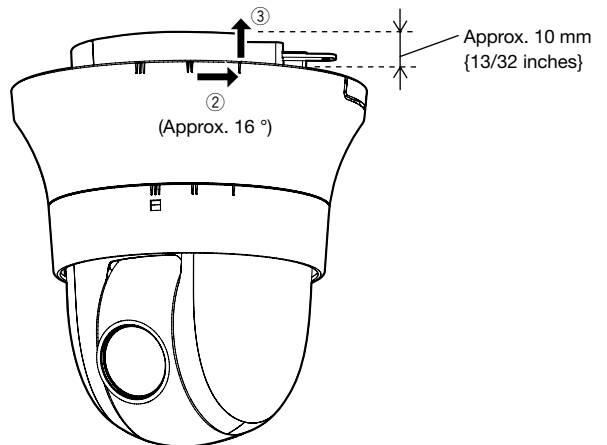

- ③ After completing ②, push up the decorative cover to the ceiling until it covers all of the fixed section of the unit.

- ④ Turn the decorative cover a further 16 ° in the direction of the arrow (clockwise) as illustrated to secure the cover.
- ⑤ Make sure that all of the end part of the locking arm has come out from the hole in the decorative cover.

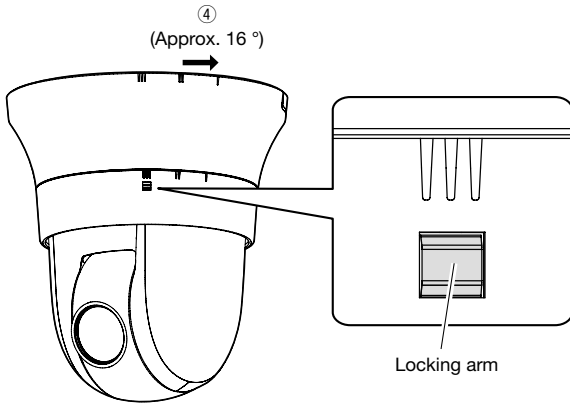

Step 11

Remove the cover film from the lens after the installation is complete.

Wire without making a hole in the ceiling

Step 1

Install the camera by following step 1 and steps 3 - 9 of the “Wire through a hole in the ceiling” section (☞ pages 19-22). It is unnecessary to make a hole in the ceiling as described in step 2 of the “Wire through a hole in the ceiling” section.

Step 2

Remove the cutout part on the decorative cover (accessory).

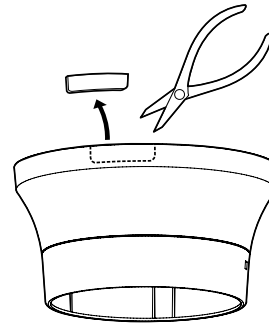

Attach the decorative cover by following step 10 of the “Wire through a hole in the ceiling” section (☞ pages 22-23). Wire through the wiring hole of the decorative cover.

- Wire through the opened area of the cutout part of the decorative cover.

[When pulling out from the side]

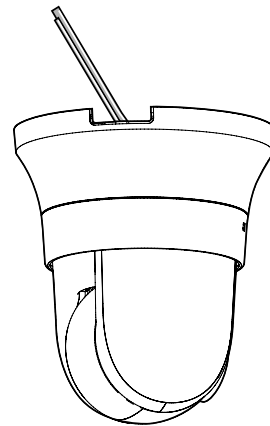

IMPORTANT:

- Make sure that no cable is pinched by the decorative cover.

Connection example

When connecting with a PC directly

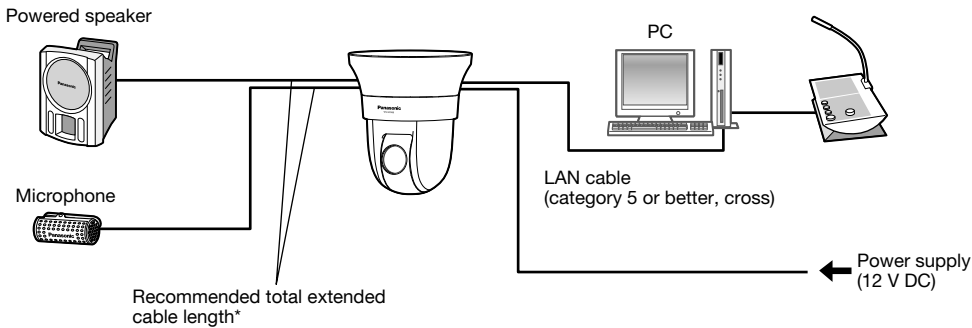

<Required cable>

LAN cable (category 5 or better, cross)

* Recommended cable length from the speaker: less than 10 m {32.8 feet}
Recommended cable length from the microphone: less than 1 m {3.28 feet}

When connecting to a network using a PoE hub

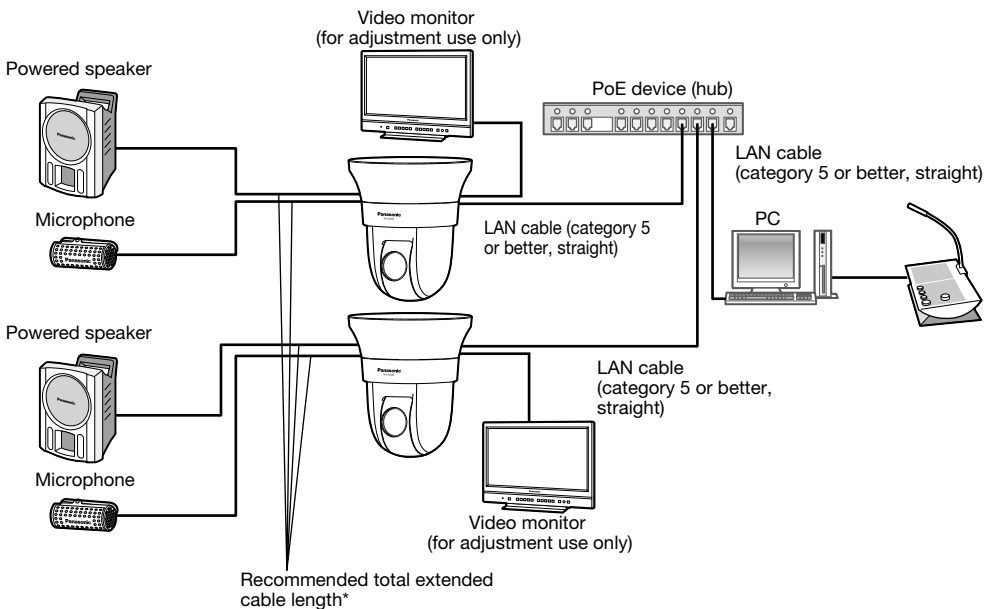

<Required cable>

LAN cable (category 5 or better, straight)

* Recommended cable length from the speaker: less than 10 m {32.8 feet}
Recommended cable length from the microphone: less than 1 m {3.28 feet}

IMPORTANT:

- The video monitor is used for checking the adjustment of the angular field of view when installing the camera or when servicing. It is not provided for recording/monitoring use.
- Depending on the monitor, some characters (camera title, preset ID, etc.) may not be displayed on the screen.
- Use a switching hub or a router which is compliant with 10BASE-T/100BASE-TX.
- If a PoE hub is not used, each network camera must be connected to a power supply.
- When using 12 V DC, power supply from a PoE hub or router is not required.

Detach the camera

The camera is fixed on the camera mount bracket using the fixing screw. Remove the camera by following the instructions below.

IMPORTANT:

- Do not detach the camera in a different way from the one described below. It may damage the camera.

Step 1

Detach the decorative cover from the camera by following step 10 of the “Wire through a hole in the ceiling” section in the reverse order (☞ pages 22-23).

- ① Turn the decorative cover by approx. 16 ° in the direction of the arrow (counterclockwise) as illustrated while pushing down the locking arm, and pull it slightly down from the ceiling.
- ② Turn the decorative cover a further 16 ° in the direction of the arrow (counterclockwise) as illustrated, and then remove the decorative cover.

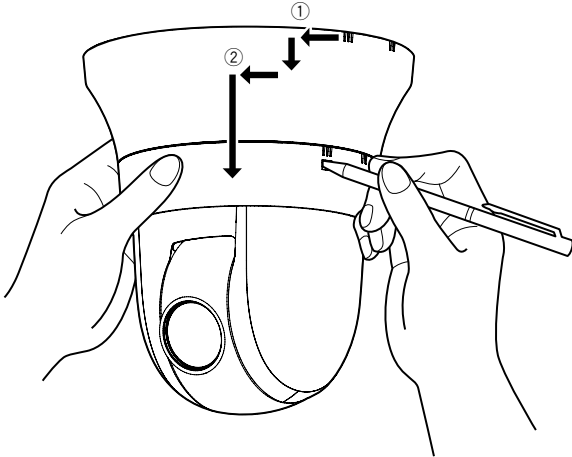

IMPORTANT:

- Hold the decorative cover with both hands when removing it. The cover will fall from the camera when the hook is disengaged from the groove.

Step 2

Detach the 12 V DC power cable plug (accessory) or the LAN cable from the camera, and then turn off the power of the camera.

Step 3

Remove the fixing screw (M3, accessory) that is fixing the camera on the camera mount bracket (accessory). Do not lose the fixing screw.

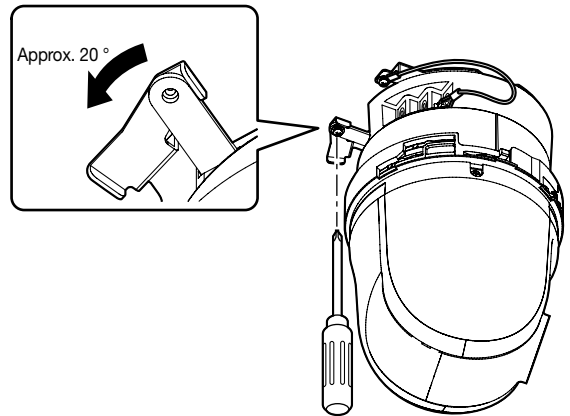

Step 4

Rotate the camera counterclockwise to detach the camera from the camera mount bracket (accessory).

IMPORTANT:

- When detaching the camera from the camera mount bracket, hold the fixed section of the unit. Detaching the camera while holding the dome section may result in malfunction.

Step 5

Disconnect the remaining cables from the camera.

Step 6

Detach the safety wire from the camera.

Configure the network settings

Configuring the camera so that it can be accessed from a PC

The following are descriptions for when the camera with default settings is configured. If you are using firewall software on your PC, the Setup Program may not be able to find any cameras on your network. Configure the setting of the camera after temporarily invalidating the firewall software. Contact the network administrator or your Internet service provider for information about configuring the settings of the network.

1 Insert the provided CD-ROM into the CD-ROM drive of your PC.

- The License Agreement will be displayed. Read the Agreement and choose “I accept the term in the license agreement”, and click [OK].
- The launcher window will be displayed. If the launcher window is not displayed, double click the “CDLauncher.exe” file on the CD-ROM.



Note:

- Refer to “Using the CD-ROM” in the Operating Instructions on the provided CD-ROM for further information about CDLauncher.

2 Click the [Run] button next to [IP Setting Software].

[Panasonic IP Setting] screen will be displayed. Click the [Network Settings] button after selecting the MAC address/IP address of the camera to be configured.

3 Select the camera you want to configure, and click [Access Camera].

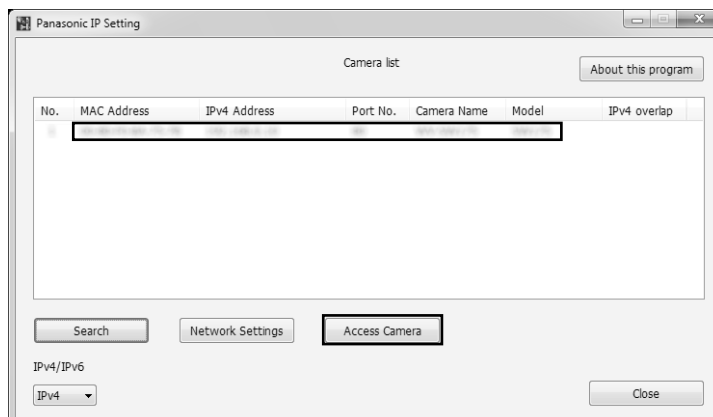

Note:

- When cameras are displayed in [Panasonic IP Setting] screen, click the camera with same MAC address as the MAC address printed on the camera that you want to configure.

4 If the installation screen of the viewer software “Network Camera View 4S” is displayed, follow the instructions of the wizard to start the installation. (The viewer software is installed from the camera.)

- The “Live” page will be displayed.
- If you cannot install the viewer software “Network Camera View 4S” or if images are not displayed, click the [Install] button next to [Viewer Software] on the launcher window to install the software.
- Perform the [Time & date] settings in the “Setup” - “Basic” page before using the camera.

Note:

- When no image is displayed on the “Live” page, refer to the Troubleshooting in the Operating Instructions on the provided CD-ROM.
 - It is possible to enhance the network security by encrypting the access to cameras using the HTTPS function. Refer to the Operating instructions on the provided CD-ROM for how to configure the HTTPS settings.
 - Click the [Setup] button on the “Live” page, the user authentication window will be displayed. Enter the default user name and password as follows, and log in.
User name: admin
Password: 12345
 - When changing settings related to the network settings, such as connection mode, IP address, and subnet mask, click the [Network Settings] button in [Panasonic IP Setting] screen as shown in step 3, then change each setting.
 - Due to security enhancements in “IP Setting Software”, “Network settings” of the camera to be configured cannot be changed when around 20 minutes have passed after turning on the power of the camera. (When the effective period is set to “20 min” in the “Easy IP Setup accommodate period”.)
However, settings can be changed after 20 minutes for cameras in the initial set mode.
 - “Network Camera Recorder with Viewer Software Lite” which supports live monitoring and recording images from multiple cameras is available. For further information, refer to our website (<http://security.panasonic.com/pss/security/support/info.html>).
-

Troubleshooting

Before asking for repairs, check the symptoms with the following table.

Contact your dealer if a problem cannot be solved even after checking and trying the solution in the table or a problem is not described below.

Symptom	Cause/solution	Reference pages
Power is not turned on.	<p>When using DC power supply</p> <ul style="list-style-type: none"> Is the 12 V DC power cable plug (accessory) firmly inserted into the 12 V DC power terminals of the camera? Confirm the power plug is firmly connected. 	22
	<p>When using a PoE device for power supply</p> <ul style="list-style-type: none"> Are the PoE device and the network connector on the rear of the camera connected using a LAN cable (category 5)? Check whether the connection is appropriately established. 	21
	<ul style="list-style-type: none"> Depending on the PoE device, the power supply will stop when the demanded power exceeds its total power limit for all PoE ports. Refer to the operating instructions of the PoE device in use. 	–
	<ul style="list-style-type: none"> When connecting both of the 12 V DC power supply and the PoE device for power supply, the network connection may not be established. Turn down the power supply from the PoE device. 	21
The camera does not move to the preset positions accurately.	<ul style="list-style-type: none"> When the preset positions becomes inaccurate during use, it is possible to correct the positions by executing the position refresh function. In addition, when “Position refresh” is set for the created schedule, the camera position will be corrected periodically. In some situations, reconfigure the preset positions. 	Operating Instructions (included in the CD-ROM)
When the camera is panning/tilting, the camera stops panning/tilting and mechanical noise comes from the camera.	<ul style="list-style-type: none"> The camera position may have become inaccurate. Carry out the refresh position function from the [Default reset] tab of the “Maintenance” page of the setup menu. 	Operating Instructions (included in the CD-ROM)
The camera starts panning unpredictably.	<ul style="list-style-type: none"> This may be caused by noise. Check the exogenous noise level around the camera. 	11
When the power is turned on, the live indicator lights or blinks orange.	<ul style="list-style-type: none"> Is the LAN cable connected appropriately? Connect the LAN cable appropriately. Is the hub or router connected to the camera operating appropriately? Check if the hub or router in use is operating appropriately. Isn't the LAN cable connected to the camera broken? Replace the cable with another one. 	21

Symptom	Cause/solution	Reference pages
Live indicator keeps on blinking orange approx. in 2 seconds intervals.	<ul style="list-style-type: none"> UPnP™ error has occurred since the power is not supplied to the router. Turn on the power of the router. Wait until the connections are established. 	-
	<ul style="list-style-type: none"> An error has occurred during the port update by the UPnP function. If the router in use does not support the UPnP function, perform the port forwarding setting for the router. In addition, deactivate the setting of auto port forwarding for the camera. 	Operating Instructions (included in the CD-ROM)
	<ul style="list-style-type: none"> UPnP function of the router is disabled. Refer to the operating instructions of the router to enable the UPnP function. 	-
Live indicator never lights up.	<ul style="list-style-type: none"> Is "Off" selected for "Link/Access LED" on the "Basic" page? Select "On" or "On(Access)" for the indicator setting. 	Operating Instructions (included in the CD-ROM)
Live indicator keeps on blinking red.	<ul style="list-style-type: none"> The camera may be out of order. Contact your dealer. Refer to the readme file on the provided CD-ROM for further information after checking the displayed contents of the "Maintenance" page - the [Status] tab - "Self check" of the setup menu. 	-
Live indicator lights red.	<ul style="list-style-type: none"> Isn't the write protect switch of the inserted SD memory card set to "LOCK"? Unlock the write protect switch of the SD memory card. Hasn't the inserted SD memory card been formatted on a PC? Use an SD memory card formatted on the camera. Or install the software to format the SD memory card on the PC. Refer to our website (http://security.panasonic.com/pss/security/support/info.html) for further information about the supported software. Isn't the inserted SD memory card faulty? Replace the card with a normal one. 	Operating Instructions (included in the CD-ROM)
Audio input contains noise.	<ul style="list-style-type: none"> Check the following. <ul style="list-style-type: none"> Grounding of the camera, a switching hub or peripheral devices are not done. The camera is used near an electrical power line. The camera is used near a device which produces strong magnetic field or radio waves (such as near a TV/radio antenna, a motor of an air conditioning system, a transformer, etc.) <p>When audio input still contains noise even after checking the above possibilities, use a powered microphone or connect audio output with low output impedance.</p>	12

About the live indicator

The live indicator will light or blink as follows depending on the camera status.

Operation status		Indicator status
When the power is turned on	Before the network connection is established	Lights orange → Lights off → Blinks orange → Lights orange
	When the network connection is established	Lights orange → Lights off → Blinks orange → Blinks green → Lights green
During the standby or connection (Cable is not connected.)		Lights orange
During the standby or connection (Cable is connected.)		Lights green
During the upgrade process		Blinks orange
During the initialization		Lights orange → Lights off → Blinks orange → Lights orange
Port forwarding error caused by the UPnP function		Blinks orange (in 2 seconds intervals (on for 1 second / off for 1 second))
Trouble happening on the camera		Blinks red
Failure in writing data on the SD memory card		Lights red

Specifications

• Basic

Power source:	12 V DC±10 %, PoE (IEEE802.3af compliant)
Power consumption:	DC power supply: 12 V DC/ 1.0 A/ 12 W PoE device: 48 V DC/ 250 mA/ Approx. 12 W (Class 0 device) * FOR UL LISTED MODEL(S), ONLY CONNECT 12 V DC CLASS 2 POWER SUPPLY (UL 1310/CSA 223) or LIMITED POWER SOURCE (IEC/EN/UL/CSA 60950-1).
Standby power *:	DC power supply: 12 V DC/ 500 mA/ 6 W PoE device: 48 V DC/ 160 mA/ Approx. 8 W (Class 0 device)
Ambient operating temperature:	-10 °C to +55 °C {14 °F to 131 °F}
Ambient operating humidity:	Less than 90 % (no condensation)
Storage temperature:	-20 °C to +65 °C {-4 °F to 149 °F}
Storage humidity:	Less than 95 % (no condensation)
Monitor output (for adjustment):	VBS: 1.0 V [p-p]/75 Ω, composite, ø3.5 mm mini jack (monaural)
External I/O terminals:	ALARM IN 1 (BLACK/WHITE IN)/ ALARM IN 2 (ALARM OUT)/ ALARM IN 3 (AUX OUT) (x1 each) BLACK/WHITE IN, ALARM OUT, and AUX OUT can be used by changing the settings of Terminal 1, Terminal 2, and Terminal 3.
Microphone/line input:	ø3.5 mm monaural mini jack Input impedance: Approx. 2 kΩ (unbalanced)
For microphone input:	Applicable microphone: Plug-in power type Supply voltage: 2.5 V ±0.5 V Recommended sensitivity of microphone: -48 dB±3 dB (0 dB=1 V/Pa, 1 kHz)
For line input:	Input level: Approx. -10 dBV
Audio output:	ø3.5 mm stereo mini jack (monaural output): Output impedance: Approx. 600 Ω (unbalanced) External speaker with an amplifier: Output level: -20 dBV
Dimensions:	ø185 mm x 211 mm (H) {ø7-9/32 inches x 8-5/16 inches (H)} (including the decorative covers)
Mass:	Camera: Approx. 1.5 kg {3.31 lbs} Accessories (Camera mount bracket, decorative cover): Approx. 240 g {0.53 lbs}
Finish:	Camera: ABS resin (Coating color: Black) Decorative cover: ABS resin (Resin color: Sail white)

* This is the power consumed when only sending video signals, and when other functions such as pan/tilt, SD recording, and the heater are not operated.

• Camera

Image sensor:	Approx. 1/3 type MOS image sensor
Effective pixels:	Approx. 2.4 megapixels
Scanning area:	5.38 mm (H) x 3.02 mm (V) {7/32 inches (H) x 1/8 inches (V)}
Scanning system:	Progressive
Minimum illumination:	Color: 0.5 lx {0.0465 foot-candle} (F1.6, Auto slow shutter: Off (1/30 s), AGC: High) 0.031 lx {0.0029 foot-candle} (F1.6, Auto slow shutter: max. 16/30 s, AGC: High)* BW: 0.06 lx {0.0056 foot-candle} (F1.6, Auto slow shutter: Off (1/30 s), AGC: High) 0.004 lx {0.0004 foot-candle} (F1.6, Auto slow shutter: max. 16/30 s, AGC: High)* * Converted value
Super-Dynamic:	On/ Off
Dynamic range:	52 dB typ. (Super Dynamic: On)
Face SD:	On/ Off
Gain (AGC):	On (Low)/ On (Mid)/ On (High)/ Off

Adaptive black stretch:	On/ Off
Back light compensation (BLC):	On/ Off
Fog compensation:	On/ Off
Light control mode setting:	Outdoor scene/ Indoor scene (50 Hz)/ Indoor scene (60 Hz)/ Fix shutter
Shutter speed:	Off (1/30), 3/100, 3/120, 2/100, 2/120, 1/100, 1/120, 1/250, 1/500, 1/1000, 1/2000, 1/4000, 1/10000
Auto slow shutter:	Off (1/30 s), max. 2/30 s, max. 4/30 s, max. 6/30 s, max. 10/30 s, max. 16/30 s
Color/BW:	On/ Off/ AUTO1/ AUTO2/ AUTO3
White balance:	ATW1/ ATW2/ AWC
Digital noise reduction:	High/ Low
Image stabilizer:	On/ Off
Privacy zone:	Gray/ Mosaic/ Off (up to 32 zones available)
Camera title on screen:	On/ Off Up to 20 characters (alphanumeric characters, marks) Character size: Large/ Middle/ Small
Video Motion Detection (VMD):	On/ Off, 4 areas available
Image hold:	On/ Off

• Lens

Zoom ratio:	30x 90x with Extra Optical Zoom (at 2 mega pixel mode: Resolution 640x360)
Digital (electronic) zoom:	12x (Max 1080x combined with Extra Optical Zoom at 2 mega pixel mode: Resolution 640x360)
Focal length:	4.3 mm - 129.0 mm {3/16 inches - 5-3/32 inches}
Maximum aperture ratio:	1:1.6 (WIDE) - 4.7 (TELE)
Focus range:	2.0 m - ∞
Aperture range:	F1.6 (WIDE) - Close
Angular field of view:	Horizontal: 2.34 ° (TELE) - 65.1 ° (WIDE) Vertical: 1.36 ° (TELE) - 38.4 ° (WIDE)

• Panning/tilting platform

Panning range:	360 ° Endless panning
Panning speed:	Manual: Approx. 0.065 °/s - 120 °/s, Preset: Up to approx. 300 °/s
Tilting range:	Operational range: -25 ° - 205 ° (level – downward – level) Selectable tilting angle: 10 °/ 5 °/ 3 °/ 0 °/ -3 °/ -5 °/ -10 °/ -15 °/ -20 °/ -25 °
Tilting speed:	Manual: Approx. 0.065 °/s - 120 °/s, Preset: Up to approx. 300 °/s
Number of the preset positions:	256
Auto mode:	Auto track/ Auto pan/ Preset sequence/ 360 map-shot/ Patrol
Self return:	10 s/ 20 s/ 30 s/ 1 min/ 2 min/ 3 min/ 5 min/ 10 min/ 20 min/ 30 min/ 60 min
Map shot:	360 map-shot/Preset map-shot

• Network

Network:	10BASE-T/100BASE-TX, RJ-45 connector
Resolution:	<ul style="list-style-type: none"> • Image capture mode: 2 mega pixel [16:9] <ul style="list-style-type: none"> H.264 1920x1080/640x360/320x180, max. 30 fps JPEG (MJPEG) 1920x1080/640x360/320x180, max. 30 fps • Image capture mode: 1.3 mega pixel [16:9] <ul style="list-style-type: none"> H.264 1280x720/640x360/320x180, max. 30 fps JPEG (MJPEG) 1280x720/640x360/320x180, max. 30 fps • Image capture mode: 1.3 mega pixel [4:3] <ul style="list-style-type: none"> H.264 1280x960/VGA/QVGA, max. 30 fps JPEG (MJPEG) 1280x960/VGA/QVGA, max. 30 fps

Image compression method:	H.264*1 Image quality: Low/ Normal/ Fine Transmission type: Unicast/Multicast Video bit rate: (Constant bit rate/Best effort/Advanced VBR) 64 kbps/ 128 kbps/ 256 kbps/ 384 kbps/ 512 kbps/ 768 kbps/ 1024 kbps/ 1536 kbps/ 2048 kbps/ 3072 kbps/ 4096 kbps/ 6144 kbps/ 8192 kbps/ 10240 kbps/ 12288 kbps/ 14336 kbps (Frame rate) 1 fps/ 3 fps/ 5 fps/ 7.5 fps/ 10 fps/ 12 fps/ 15 fps/ 20 fps/ 30 fps JPEG (MJPEG) Image quality: 0 SUPER FINE/ 1 FINE/ 2/ 3/ 4/ 5 NORMAL/ 6/ 7/ 8/ 9 LOW (10 steps: 0-9) Transmission type: PULL/PUSH
Transmission interval:	0.1 fps - 30 fps (JPEG frame rate will be restricted when displaying both JPEG and H.264 images.)
Audio compression method:	G.726 (ADPCM) 32 kbps/ 16 kbps, G.711 64 kbps, AAC*2
Bandwidth control:	Unlimited/ 64 kbps/ 128 kbps/ 256 kbps/ 384 kbps/ 512 kbps/ 768 kbps/ 1024 kbps/ 2048 kbps/ 4096 kbps/ 8192 kbps
Protocol:	IPv6: TCP/IP, UDP/IP, HTTP, HTTPS, FTP, SMTP, DNS, NTP, SNMP, DHCPv6, RTP, MLD, ICMP, ARP IPv4: TCP/IP, UDP/IP, HTTP, HTTPS, RTSP, RTP, RTP/RTCP, FTP, SMTP, DHCP, DNS, DDNS, NTP, SNMP, UPnP, IGMP, ICMP, ARP
OS*3 *4:	Microsoft Windows 8 Microsoft Windows 7 Microsoft Windows Vista Microsoft Windows XP SP3
Browser:	Windows Internet Explorer 10.0 (32-bit) Windows Internet Explorer 9.0 (32-bit) Windows Internet Explorer 8.0 (32-bit) Windows Internet Explorer 7.0 (32-bit)
Maximum concurrent access number:	14 (Number of sessions that can connect to cameras at the same time) * Depends on network conditions
FTP client:	Alarm image transmission, FTP periodic transmission (When the FTP transmission is failed, backup on an optional SD memory card is available.)
Multi-screen:	Up to 16 camera images can be displayed simultaneously on a multi-screen. (Including the camera itself)
Compatible SDXC/SDHC/SD memory card:	Manufactured by Panasonic (SD speed class 4 or higher) SDXC memory card: 64 GB SDHC memory card: 4 GB, 8 GB, 16 GB, 32 GB SD memory card: 2 GB (except miniSD card and microSD card)
Cellular phone compatibility:	JPEG image, panning/ tilting/ zoom/ focus control, AUX control (by access level)
Mobile terminal compatibility: (As of February, 2013)*5	iPad, iPhone, iPod touch (iOS 4.2.1 or later) Android™ mobile terminals

*1 Transmission for 2 streams can be individually set.

*2 AAC (Advanced Audio Coding) is only used when recording audio on an SD memory card.

*3 For further information about PC system requirements and precautions for when using Microsoft Windows 8, Microsoft Windows 7, Microsoft Windows Vista, or Windows Internet Explorer, click "Manual" - "Open" from the supplied CD-ROM and refer to "Notes on Windows® / Internet Explorer® versions".

*4 When using IPv6 for communication, use Microsoft Windows 8, Microsoft Windows 7 or Microsoft Windows Vista.

*5 For further information about compatible devices, refer to our website
(<http://security.panasonic.com/pss/security/support/info.html>).

Standard accessories

Installation Guide (this document)	1 pc.
Warranty card	1 set
CD-ROM*1	1 pc.
Code label*2	1 pc.

*1 The CD-ROM contains the operating instructions and different kinds of tool software programs.

*2 This label may be required for network management. The network administrator shall retain the code label.

The following parts are used during installation procedures.

Camera mount bracket	1 pc.
Camera fixing screw (M3)	2 pcs. (incl. 1 spare)
Decorative cover (upper part and lower part)	1 pc.
Power cable plug	1 pc.

Optional accessories

Wall Mount Bracket	WV-Q119
Ceiling Embedding Bracket	WV-Q126A
Ceiling Mount Bracket	WV-Q105
Smoke dome cover	WV-CS5S
Clear dome cover	WV-CS5C
User License Accessory (For H.264)	BB-HCA8A BB-HCA8CE

Information for Users on Collection and Disposal of Old Equipment and used Batteries



These symbols on the products, packaging, and/or accompanying documents mean that used electrical and electronic products and batteries should not be mixed with general household waste.

For proper treatment, recovery and recycling of old products and used batteries, please take them to applicable collection points, in accordance with your national legislation and the Directives 2002/96/EC and 2006/66/EC.

By disposing of these products and batteries correctly, you will help to save valuable resources and prevent any potential negative effects on human health and the environment which could otherwise arise from inappropriate waste handling.

For more information about collection and recycling of old products and batteries, please contact your local municipality, your waste disposal service or the point of sale where you purchased the items.

Penalties may be applicable for incorrect disposal of this waste, in accordance with national legislation.



For business users in the European Union

If you wish to discard electrical and electronic equipment, please contact your dealer or supplier for further information.

[Information on Disposal in other Countries outside the European Union]

These symbols are only valid in the European Union. If you wish to discard these items, please contact your local authorities or dealer and ask for the correct method of disposal.



Note for the battery symbol (bottom two symbol examples):

This symbol might be used in combination with a chemical symbol. In this case it complies with the requirement set by the Directive for the chemical involved.

Cd

For U.S. and Canada:

Panasonic System Communications Company of North America, Unit of Panasonic Corporation of North America

www.panasonic.com/business/

For customer support, call 1.800.528.6747

Three Panasonic Way, Secaucus, New Jersey 07094 U.S.A.

Panasonic Canada Inc.

5770 Ambler Drive, Mississauga, Ontario, L4W 2T3 Canada

(905)624-5010

www.panasonic.ca

For Europe and other countries:

Panasonic Corporation

<http://panasonic.net>

Panasonic System Networks Co., Ltd.
Fukuoka, Japan

Authorised Representative in EU:



Panasonic Testing Centre
Panasonic Marketing Europe GmbH
Winsbergring 15, 22525 Hamburg, Germany