

Panasonic

Installation Guide

Network Camera

Model No. **WV-SW355PJ**

WV-SW355, WV-SW352

WV-SW355E, WV-SW352E

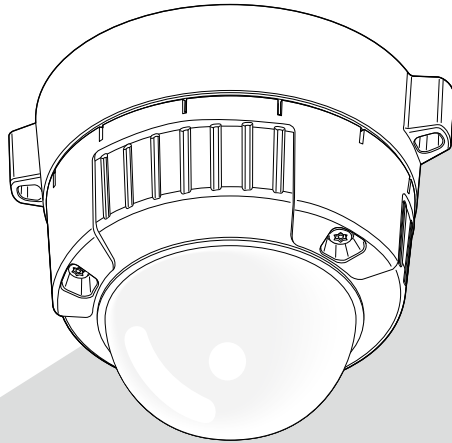

Before attempting to connect or operate this product, please read these instructions carefully and save this manual for future use.

The model number is abbreviated in some descriptions in this manual.

WARNING:

- Apparatus shall be connected to a mains socket outlet with a protective earthing connection.
- The mains plug or an appliance coupler shall remain readily operable.
- The apparatus should not be exposed to dripping or splashing and that no objects filled with liquids, such as vases, should be placed on the apparatus.
- All work related to the installation of this product should be made by qualified service personnel or system installers.
- For PERMANENTLY CONNECTED APPARATUS provided neither with an all-pole MAINS SWITCH nor an all-pole circuit breaker, the installation shall be carried out in accordance with all applicable installation rules.
- The connections should comply with local electrical code.



The lightning flash with arrow-head symbol, within an equilateral triangle, is intended to alert the user to the presence of uninsulated "dangerous voltage" within the product's enclosure that may be of sufficient magnitude to constitute a risk of electric shock to persons.



The exclamation point within an equilateral triangle is intended to alert the user to the presence of important operating and maintenance (servicing) instructions in the literature accompanying the appliance.

Power disconnection. Unit with or without ON-OFF switches have power supplied to the unit whenever the power cord is inserted into the power source; however, the unit is operational only when the ON-OFF switch is in the ON position. Unplug the power cord to disconnect the main power for all units.

For U.S. and Canada:
WV-SW355, WV-SW355PJ, WV-SW352
For Europe and other countries:
WV-SW355E, WV-SW352E

UL listed model No.
WV-SW355, WV-SW355PJ, WV-SW352

For Canada
This Class A digital apparatus complies with Canadian ICES-003.

For U.S.A

NOTE: This equipment has been tested and found to comply with the limits for a Class A digital device, pursuant to Part 15 of the FCC Rules. These limits are designed to provide reasonable protection against harmful interference when the equipment is operated in a commercial environment. This equipment generates, uses, and can radiate radio frequency energy and, if not installed and used in accordance with the instruction manual, may cause harmful interference to radio communications. Operation of this equipment in a residential area is likely to cause harmful interference in which case the user will be required to correct the interference at his own expense.

FCC Caution: To assure continued compliance, (example - use only shielded interface cables when connecting to computer or peripheral devices). Any changes or modifications not expressly approved by the party responsible for compliance could void the user's authority to operate this equipment.

For U.S.A

The serial number of this product may be found on the surface of the unit. You should note the model number and serial number of this unit in the space provided and retain this book as a permanent record of your purchase to aid identification in the event of theft.

Model No. _____
Serial No. _____

We declare under our sole responsibility that the product to which this declaration relates is in conformity with the standards or other normative documents following the provisions of Directives 2006/95/EC and 2004/108/EC.

Wir erklären in alleiniger Verantwortung, daß das Produkt, auf das sich diese Erklärung bezieht, mit den folgenden Normen oder normativen Dokumenten übereinstimmt. Gemäß den Bestimmungen der Richtlinie 2006/95/EC und 2004/108/EC.

Nous déclarons sous notre propre responsabilité que le produit auquel se réfère la présente déclaration est conforme aux normes spécifiées ou à tout autre document normatif conformément aux dispositions des directives 2006/95/CE et 2004/108/CE.

Nosotros declaramos bajo nuestra única responsabilidad que el producto a que hace referencia esta declaración está conforme con las normas u otros documentos normativos siguiendo las estipulaciones de las directivas 2006/95/CE y 2004/108/CE.

Noi dichiariamo sotto nostra esclusiva responsabilità che il prodotto a cui si riferisce la presente dichiarazione risulta conforme ai seguenti standard o altri documenti normativi conformi alle disposizioni delle direttive 2006/95/CE e 2004/108/CE.

Wij verklaren als enige aansprakelijke, dat het product waarop deze verklaring betrekking heeft, voldoet aan de volgende normen of andere normatieve documenten, overeenkomstig de bepalingen van Richtlijnen 2006/95/EC en 2004/108/EC.

Vi erklærer os eneansvarlige for, at dette produkt, som denne deklaration omhandler, er i overensstemmelse med standarder eller andre normative dokumenter i følge bestemmelserne i direktivene 2006/95/EC og 2004/108/EC.

Vi deklarerar härmed vårt fulla ansvar för att den produkt till vilken denna deklaration hänvisar är i överensstämmelse med de standarder eller andra normativa dokument som framställs i direktiv nr 2006/95/EC och 2004/108/EC.

Ilmoitamme yksinomaisella vastuullamme, että tuote, jota tämä ilmoitus koskee, noudattaa seuraavia standardeja tai muita ohjeellisia asiakirjoja, jotka noudattavat direktiivien 2006/95/EC ja 2004/108/EC säädöksiä.

Vi erklærer oss alene ansvarlige for at produktet som denne erklæringen gjelder for, er i overensstemmelse med følgende normer eller andre normgivende dokumenter som følger bestemmelsene i direktivene 2006/95/EC og 2004/108/EC.

Contents

Important safety instructions.....	5
Limitation of liability.....	6
Disclaimer of warranty.....	6
Preface	7
Main functions.....	7
About the user manuals	8
System requirements for a PC	8
Trademarks and registered trademarks.....	9
Copyright.....	9
Network security	10
Precautions	11
Precautions for installation.....	14
Major operating controls	16
Preparations	18
Insert/remove an SDHC/SD memory card	23
How to install the heater unit.....	24
Connection	26
Installation	31
Adjustment	36
Configure the network settings	41
Troubleshooting.....	43
Specifications.....	44
Standard accessories.....	48
Optional accessories.....	49

Important safety instructions

- 1) Read these instructions.
- 2) Keep these instructions.
- 3) Heed all warnings.
- 4) Follow all instructions.
- 5) Clean only with dry cloth.
- 6) Do not block any ventilation openings. Install in accordance with the manufacturer's instructions.
- 7) Do not install near any heat sources such as radiators, heat registers, stoves, or other apparatus (including amplifiers) that produce heat.
- 8) Do not defeat the safety purpose of the polarized or grounding-type plug. A polarized plug has two blades with one wider than the other. A grounding type plug has two blades and a third grounding prong. The wide blade or the third prong are provided for your safety. If the provided plug does not fit into your outlet, consult an electrician for replacement of the obsolete outlet.
- 9) Protect the power cord from being walked on or pinched particularly at plugs, convenience receptacles, and the point where they exit from the apparatus.
- 10) Only use attachments/accessories specified by the manufacturer.
- 11) Use only with the cart, stand, tripod, bracket, or table specified by the manufacturer, or sold with the apparatus. When a cart is used, use caution when moving the cart/apparatus combination to avoid injury from tip-over.



- 12) Unplug this apparatus during lightning storms or when unused for long periods of time.

Limitation of liability

THIS PUBLICATION IS PROVIDED "AS IS" WITHOUT WARRANTY OF ANY KIND, EITHER EXPRESS OR IMPLIED, INCLUDING BUT NOT LIMITED TO, THE IMPLIED WARRANTIES OF MERCHANTABILITY, FITNESS FOR ANY PARTICULAR PURPOSE, OR NON-INFRINGEMENT OF THE THIRD PARTY'S RIGHT.

THIS PUBLICATION COULD INCLUDE TECHNICAL INACCURACIES OR TYPOGRAPHICAL ERRORS. CHANGES ARE ADDED TO THE INFORMATION HEREIN, AT ANY TIME, FOR THE IMPROVEMENTS OF THIS PUBLICATION AND/OR THE CORRESPONDING PRODUCT (S).

Disclaimer of warranty

IN NO EVENT SHALL Panasonic System Networks Co., Ltd. BE LIABLE TO ANY PARTY OR ANY PERSON, EXCEPT FOR REPLACEMENT OR REASONABLE MAINTENANCE OF THE PRODUCT, FOR THE CASES, INCLUDING BUT NOT LIMITED TO BELOW:

- (1) ANY DAMAGE AND LOSS, INCLUDING WITHOUT LIMITATION, DIRECT OR INDIRECT, SPECIAL, CONSEQUENTIAL OR EXEMPLARY, ARISING OUT OF OR RELATING TO THE PRODUCT;
- (2) PERSONAL INJURY OR ANY DAMAGE CAUSED BY INAPPROPRIATE USE OR NEGLIGENT OPERATION OF THE USER;
- (3) UNAUTHORIZED DISASSEMBLE, REPAIR OR MODIFICATION OF THE PRODUCT BY THE USER;
- (4) INCONVENIENCE OR ANY LOSS ARISING WHEN IMAGES ARE NOT DISPLAYED, DUE TO ANY REASON OR CAUSE INCLUDING ANY FAILURE OR PROBLEM OF THE PRODUCT;
- (5) ANY PROBLEM, CONSEQUENTIAL INCONVENIENCE, OR LOSS OR DAMAGE, ARISING OUT OF THE SYSTEM COMBINED BY THE DEVICES OF THIRD PARTY;
- (6) ANY CLAIM OR ACTION FOR DAMAGES, BROUGHT BY ANY PERSON OR ORGANIZATION BEING A PHOTOGENIC SUBJECT, DUE TO VIOLATION OF PRIVACY WITH THE RESULT OF THAT SURVEILLANCE-CAMERA'S PICTURE, INCLUDING SAVED DATA, FOR SOME REASON, BECOMES PUBLIC OR IS USED FOR ANY PURPOSE;
- (7) LOSS OF REGISTERED DATA CAUSED BY ANY FAILURE.

Preface

The network cameras WV-SW355/WV-SW352 are designed to operate using a PC on a network (10BASE-T/100BASE-TX), and can be installed under eaves (sheltered outdoor). By connecting to a network (LAN) or the Internet, images and audio from the camera can be monitored on a PC via a network.

Note:

- It is necessary to configure the network settings of the PC and its network environment to monitor images from the camera on the PC. It is also necessary to install a web browser on the PC.
-

Main functions

Introduction of Super Dynamic **(Operating Instructions (PDF))**

Super Dynamic compensates brightness on a pixel-to-pixel basis so that it produces clearer images even if objects have various illumination intensities.

H.264/MPEG-4 and JPEG triple encoding

H.264/MPEG-4 dual stream output and JPEG output can be simultaneously provided.

- * Either H.264 or MPEG-4 is selectable.

Auto focus (AF) function

It is possible to adjust the focus automatically by moving the focus ring of the lens with the operation button of this camera or the setup menu.

Black & white mode

Images will be displayed clear even at night since the camera will be automatically switched from the color mode to the black and white mode under low illumination condition.

Power over Ethernet function

When connecting with a PoE (Power over Ethernet) device, power will be supplied by simply connecting a LAN cable. (IEEE802.3af compliant)

Interactive communication with audio

By using the audio output connector and the microphone in connector, receiving audio from the cameras on a PC and transmitting audio from the PC to the cameras is available.

SDHC/SD memory card slot equipped

It is possible to save H.264 videos and JPEG images on the SDHC/SD memory card manually at an alarm occurrence, during the period of the schedule, or on a web browser. It is also possible to save JPEG images at a network failure occurrence. (Download is possible.)
(Recommended SDHC/SD memory card  page 47)

About the user manuals

There are 2 sets of operating instructions for the WV-SW355, WV-SW355PJ, WV-SW352 (NTSC model), WV-SW355E, WV-SW352E (PAL model) as follows.

- Installation Guide: Explains how to install and connect devices.
- Operating Instructions (PDF): Explains how to perform the settings and how to operate this camera.

Adobe® Reader® is required to read these operating instructions (PDF) on the provided CD-ROM. When the Adobe® Reader® is not installed on the PC, download the latest Adobe® Reader® from the Adobe web site and install it.

"WV-SW355, WV-SW352" or "SW355, SW352" shown in the instructions and illustrations used in these operating instructions indicates the WV-SW355, WV-SW355PJ, WV-SW352, WV-SW355E, WV-SW352E.

The screens used in these operating instructions show the cases of NTSC models.

System requirements for a PC

CPU:	Intel® Core™ 2 Duo 2.4 GHz or faster recommended
Memory:	512 MB or more (A minimum of 1 GB memory is required when using Microsoft® Windows® 7 or Microsoft® Windows Vista®.)
Network interface:	10BASE-T/100BASE-TX 1 port
Audio interface:	Sound card (when using the audio function)
Monitor:	Image capture size: 1024 x 768 pixels or more Color: 24-bit True color or better
OS:	Microsoft® Windows® 7 Professional (64-bit) Microsoft® Windows® 7 Professional (32-bit) Microsoft® Windows Vista® Business SP1 (32-bit) Microsoft® Windows® XP Professional SP3
Web browser:	Windows® Internet Explorer® 8.0 (32-bit) (Microsoft® Windows® 7 Professional (32-bit/64-bit)) Windows® Internet Explorer® 7.0 (Microsoft® Windows Vista® Business SP1 (32-bit)) Microsoft® Internet Explorer® 6.0 SP3 (Microsoft® Windows® XP Professional SP3)
Others:	CD-ROM drive (It is necessary to read the operating instructions and use the software on the provided CD-ROM.) DirectX® 9.0c or later Adobe® Reader® (It is necessary to read the operating instructions on the provided CD-ROM.)

Important:

- When using a PC that does not meet the above requirements, displaying of images may become slower or the web browser may become inoperable.
 - Audio may not be heard if a sound card is not installed on a PC. Audio may be interrupted depending on the network environment.
 - Microsoft® Windows® XP Professional 64-bit Edition is not supported.
 - When using IPv6 for communication, use Microsoft® Windows® 7 or Microsoft® Windows Vista®.
-

Note:

- Refer to "Notes on Windows Vista® / Windows® 7" (PDF) on the provided CD-ROM for further information about system requirements for a PC and precautions when using Microsoft® Windows® 7 or Microsoft® Windows Vista®.
- If using Microsoft® Windows® XP, screen tearing* may occur when the shooting scene drastically changes (for example, while shooting fast-moving subjects) due to the GDI restrictions of the OS.

* A phenomenon in which portions of the screen are displayed out of alignment

Trademarks and registered trademarks

- Adobe, the Adobe logo, and Reader are either registered trademarks or trademarks of Adobe Systems Incorporated in the United States and/or other countries.
- Microsoft, Windows, Windows Vista, Internet Explorer, ActiveX, and DirectX are either registered trademarks or trademarks of Microsoft Corporation in the United States and/or other countries.
- Microsoft product screen shot(s) reprinted with permission from Microsoft Corporation.
- Intel and Intel Core are trademarks or registered trademarks of Intel Corporation or its subsidiaries in the United States and other countries.
- SDHC Logo is a trademark of SD-3C, LLC.
- All other trademarks identified herein are the property of their respective owners.

Copyright

Distributing, copying, disassembling, reverse compiling and reverse engineering of the software provided with this product are all expressly prohibited. In addition, exporting any software provided with this product violating export laws is prohibited.

Network security

As you will use this unit connected to a network, your attention is called to the following security risks.

- ① Leakage or theft of information through this unit
- ② Use of this unit for illegal operations by persons with malicious intent
- ③ Interference with or stoppage of this unit by persons with malicious intent

It is your responsibility to take precautions such as those described below to protect yourself against the above network security risks.

- Use this unit in a network secured by a firewall, etc.
- If this unit is connected to a network that includes PCs, make sure that the system is not infected by computer viruses or other malicious entities (using a regularly updated anti-virus program, anti-spyware program, etc.).
- Protect your network against unauthorized access by restricting users to those who log in with an authorized user name and password.
- Apply measures such as user authentication to protect your network against leakage or theft of information, including image data, authentication information (user names and passwords), alarm mail information, FTP server information and DDNS server information.
- After the unit is accessed by the administrator, make sure to close the browser.
- Change the administrator password periodically.
- Do not install the camera in locations where the camera or the cables can be destroyed or damaged by persons with malicious intent.

Precautions

Refer installation work to the dealer.

Installation work requires technique and experiences. Failure to observe this may cause fire, electric shock, injury, or damage to this product.

Be sure to consult the dealer.

Stop the operation immediately when something is wrong with this product.

When smoke goes up from the product, the smell of smoke comes from the product, or the exterior of the product has deteriorated, continued use will cause a fire or fall of the product resulting in injury, accidents, or damage to the product.

Turn the power off immediately and contact qualified service personnel for service.

Do not attempt to disassemble or modify this product.

Failure to observe this may cause fire or electric shock.

Consult the dealer for the repair or inspections.

Do not insert any foreign objects.

This could permanently damage this product.

Turn the power off immediately and contact qualified service personnel for service.

Select an installation area that can support the total weight.

Selecting an inappropriate installation surface may cause this product to fall down or topple over, resulting in injury.

Installation work shall be started after sufficient reinforcement.

Periodic inspections shall be conducted.

Rust on the metal parts or screws may cause a fall of the product resulting in injury or accidents.

Consult the dealer for the inspections.

Do not use this product in an inflammable atmosphere.

Failure to observe this may cause an explosion resulting in injury.

Avoid installing this product in the locations where salt damage occurs or corrosive gas is produced.

Otherwise, the mounting portions will deteriorate and accidents such as a fall of the product may occur.

Do not install this product in locations subject to vibration.

Loosening of mounting screws or bolts may cause a fall of the product resulting in injury.

Install this product in a location high enough to avoid people and objects from bumping the product.

Failure to observe this may cause a drop resulting in injury or accidents.

Do not strike or give a strong shock to this product.

Failure to observe this may cause fire or injury.

Turn the power off when do wiring of this product.

Failure to observe this may cause electric shock. In addition, short circuit or wrong wiring may cause fire.

The exclusively designed mount bracket shall be used.

Failure to observe this may cause a drop resulting in injury or accidents.

Use the exclusively designed mount bracket for installation.

The screws and bolts must be tightened to the specified torque.

Failure to observe this may cause a drop resulting in injury or accidents.

Do not rub the edges of metal parts with your hand.

Failure to observe this may cause injury.

Do not touch this product, the power cord or the connected cables during thunder. (even in the process of work)

Failure to observe this may cause electric shock.

Turn the power off when cleaning this product.

Failure to observe this may cause injury.

[Precautions for use]

This product has no power switch.

When turning off the power, turn off a circuit breaker.

To keep on using with stable performance

Do not use this product in hot and humid conditions for a long time. Failure to observe this causes component degradation resulting in life shortening of this product.

Do not expose the product to direct heat sources such as a heater.

Do not touch the dome cover with your bare hands.

A dirty dome cover causes deterioration of picture quality.

Handle this product with care.

Do not drop this product, nor apply shock or vibration to the product. Failure to observe this may cause trouble. If a strong shock or vibration is applied to the enclosure, it may cause damage or allow water to enter this product.

About the PC monitor

Displaying the same image on a monitor for a long time may damage the monitor. It is recommended to use a screen-saver.

Product disposal/transfer

Images saved on the SDHC/SD memory card may lead to personal information leakage. When it is necessary to dispose or give this product to someone, even when for repair, make sure that there is no data on the hard disk drives.

Cleaning this product body

Be sure to turn off the power before cleaning. Failure to observe this may cause injury. Do not use strong abrasive detergent when cleaning this product. Otherwise, it may cause discoloration. When using a chemical cloth for cleaning, read the caution provided with the chemical cloth product.

Cleaning the lens

Use a lens cleaning paper (used to clean camera lenses or lenses of spectacles). When using solvent, use an alcohol solvent and do not use a thinner or a glass cleaner.

Transmission interval

Image transmission interval may become slow depending on the network environment, PC performance, shooting subject, access number, etc.

About SDHC/SD memory card

- Before inserting the SDHC/SD memory card, turn off the power of this product first. Otherwise, it may cause malfunction or damage data recorded on the SDHC/SD memory card. Refer to page 23 for descriptions of how to insert/remove an SDHC/SD memory card.
- When using an SDHC/SD memory card, format it using this product. Recorded data on the SDHC/SD memory card will be deleted when formatted. If an unformatted SDHC/SD memory card or an SDHC/SD memory card formatted with other devices is used, this product may not work properly or performance deterioration may be caused. Refer to the Operating Instructions (PDF) for how to format a SDHC/SD memory card.

- When some SDHC/SD memory cards are used with this product, the product may not work properly or performance deterioration may be caused. Use the SDHC/SD memory cards recommended in page 47.

Code label

The code labels (accessory) are required at inquiry for trouble. Use caution not to lose these labels. It is recommended to paste one of the labels onto the CD-ROM case.

Discoloration on the color filter of the MOS image sensor

- When continuously shooting a bright light source such as a spotlight, the color filter of the MOS image sensor may have deteriorated and it may cause discoloration. Even when changing the fixed shooting direction after continuously shooting a spotlight for a certain period, the discoloration may remain.
- When shooting fast-moving subjects or performing panning/tilting operations, objects crossing the shooting area may look to be bending askew.

MPEG-4 Visual Patent Portfolio License

This product is licensed under the MPEG-4 Visual Patent Portfolio License for the personal and non-commercial use of a consumer for (i) encoding video in compliance with the MPEG-4 Visual Standard ("MPEG-4 Video") and/or (ii) decoding MPEG-4 Video that was encoded by a consumer engaged in a personal and non-commercial activity and/or was obtained from a video provider licensed by MPEG LA to provide MPEG-4 Video. No license is granted or shall be implied for any other use. Additional information including that relating to promotional, internal and commercial uses and licensing may be obtained from MPEG LA, LLC.

See <http://www.mpegla.com>.

AVC Patent Portfolio License

THIS PRODUCT IS LICENSED UNDER THE AVC PATENT PORTFOLIO LICENSE FOR THE PERSONAL USE OF A CONSUMER OR OTHER USES IN WHICH IT DOES NOT RECEIVE REMUNERATION TO (i) ENCODE VIDEO IN COMPLIANCE WITH THE AVC STANDARD ("AVC VIDEO") AND/OR (ii) DECODE AVC VIDEO THAT WAS ENCODED BY A CONSUMER ENGAGED IN A PERSONAL ACTIVITY AND/OR WAS OBTAINED FROM A VIDEO PROVIDER LICENSED TO PROVIDE AVC VIDEO. NO LICENSE IS GRANTED OR SHALL BE IMPLIED FOR ANY OTHER USE. ADDITIONAL INFORMATION MAY BE OBTAINED FROM MPEG LA, L.L.C.

SEE [HTTP://WWW.MPEGLA.COM](http://WWW.MPEGLA.COM)

Indication label

Refer to the indication label placed on the bottom of this product for the equipment classification and power source, etc.

About the dehumidifying device

- This product has dehumidifying device to keep the inside at low moisture level, preventing condensation and quickly dissipating dew if produced.
- Dew may be produced depending on the conditions of temperature, humidity, winds, and rain, and it may take time to dehumidify.
- Never seal the surfaces of the dehumidifying device.

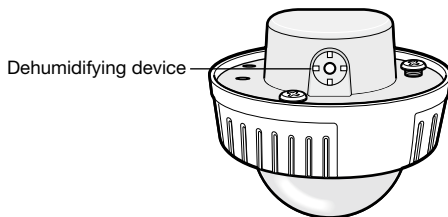

Precautions for installation

Panasonic assumes no responsibility for injuries or property damage resulting from failures arising out of improper installation or operation inconsistent with this documentation.

This product is designed to be installed under eaves.

Install the product under eaves to avoid direct sunlight.

Installing place

Contact your dealer for assistance if you are unsure of an appropriate place in your particular environment.

- Make sure that the installation area is strong enough to hold this product, such as a concrete ceiling.
- Install the camera in the foundation area of the architecture or where sufficient strength is assured.
- If a ceiling board such as plaster board is too weak to support the total weight, the area shall be sufficiently reinforced.

Do not place this product in the following places:

- Locations where a chemical agent is used such as a swimming pool
- Locations subject to humidity, dust, steam and oil smoke
- Locations where a radiation, an X-ray, a strong radio wave or a strong magnetic field is generated
- Locations where corrosive gas is produced, locations where it may be damaged by briny air such as seashores
- Locations where the temperature is not within the specified range (page 44).
- Locations subject to vibrations (This product is not designed for on-vehicle use.)
- If a ceiling board such as plaster board is too weak to support the total weight, the area shall be sufficiently reinforced.

Do not install this product in a humid or dust-laden environment.

Otherwise, lifetime of the internal parts may be shortened.

Be sure to remove this product if it is not in use.

Design and engineer the power supply system to turn on/off the power of this product.

The product has no power switch. When installing the product, use a power supply device equipped with the ON-OFF switch for servicing.

About the network connection

When connecting to a network using the network cable of this product, observe the following.

- When wiring for the network, design and engineer not to be affected by thunder.
- It is impossible to install this product in combination with a pan/tilt head.

Screw tightening

- The screws and bolts must be tightened with an appropriate tightening torque according to the material and strength of the installation area.
- Do not use an impact driver. Use of an impact driver may damage the screws or cause tightening excessively.
- Tighten screws at a right angle to the surface. After tightening screws, perform visual check to ensure tightening is so sufficient that there is no backlash.

Procure fixing screws separately.

The screws that secure this product are not supplied. Prepare them according to the material and strength of the area where the product is to be installed.

Do not remove or loosen the screws on the rear of this product.

If the screws (7 pcs.) are loosened, water exposure may cause damage or malfunction of the product, or dropping may result in injury.

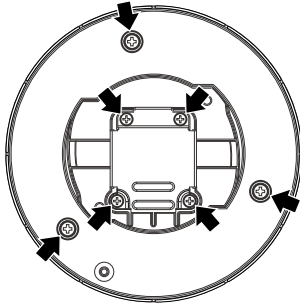

Radio disturbance

When this product is used near TV/radio antenna, strong electric field or magnetic field (near a motor, a transformer or a power line), images may be distorted and noise sound may be produced.

PoE (Power over Ethernet)

Use a PoE hub/device that is compliant with IEEE802.3af standard.

Router

When connecting this product to the Internet, use a broadband router with the port forwarding function (NAT, IP masquerade).

Refer to the Operating Instructions (PDF) for further information about the port forwarding function.

Time & date setting

It is necessary to set the time & date before putting this product into operation. Refer to the Operating Instructions (PDF) on the provided CD-ROM for descriptions of how to perform the settings.

Major operating controls

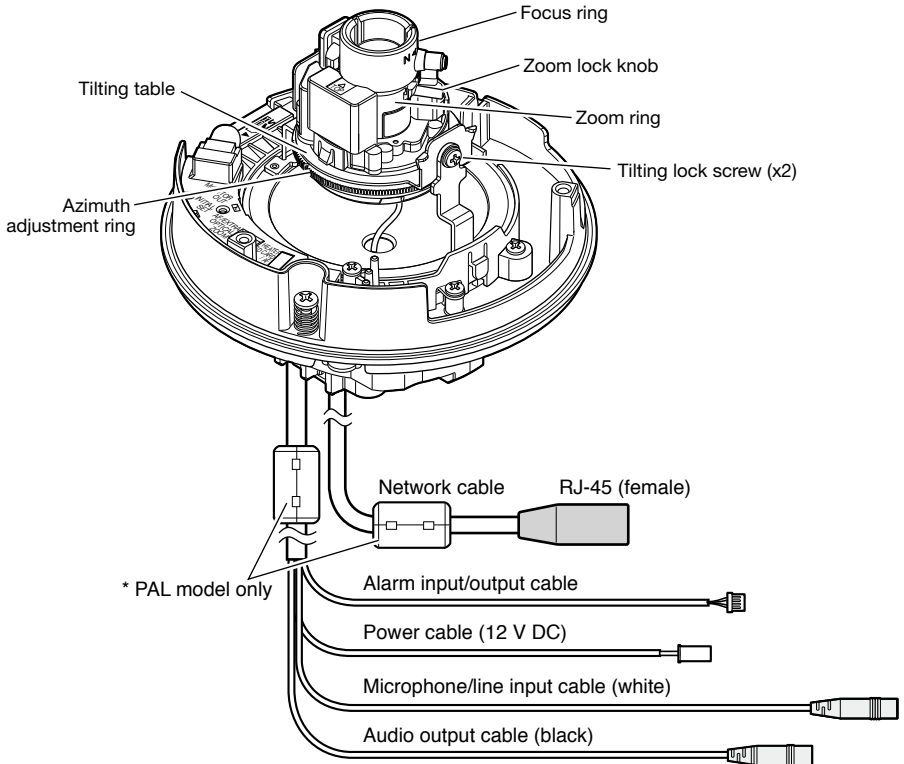
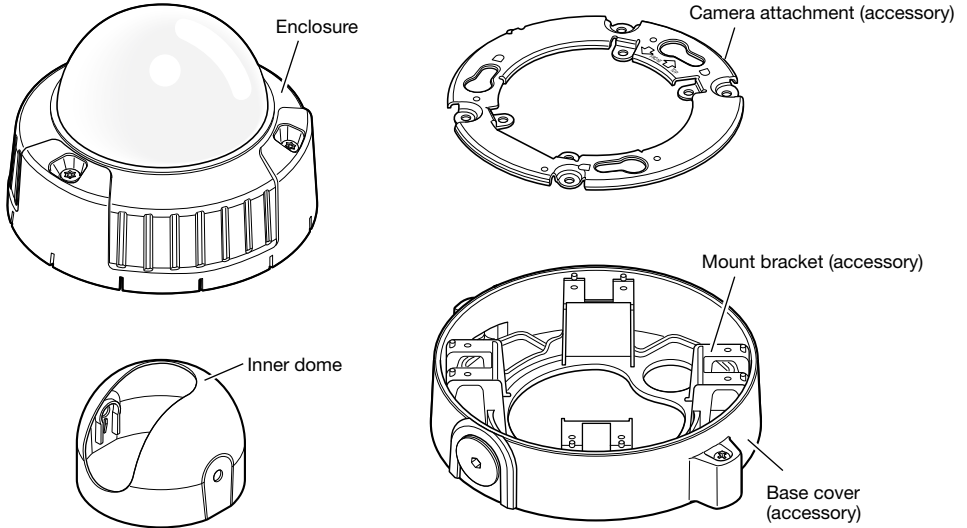

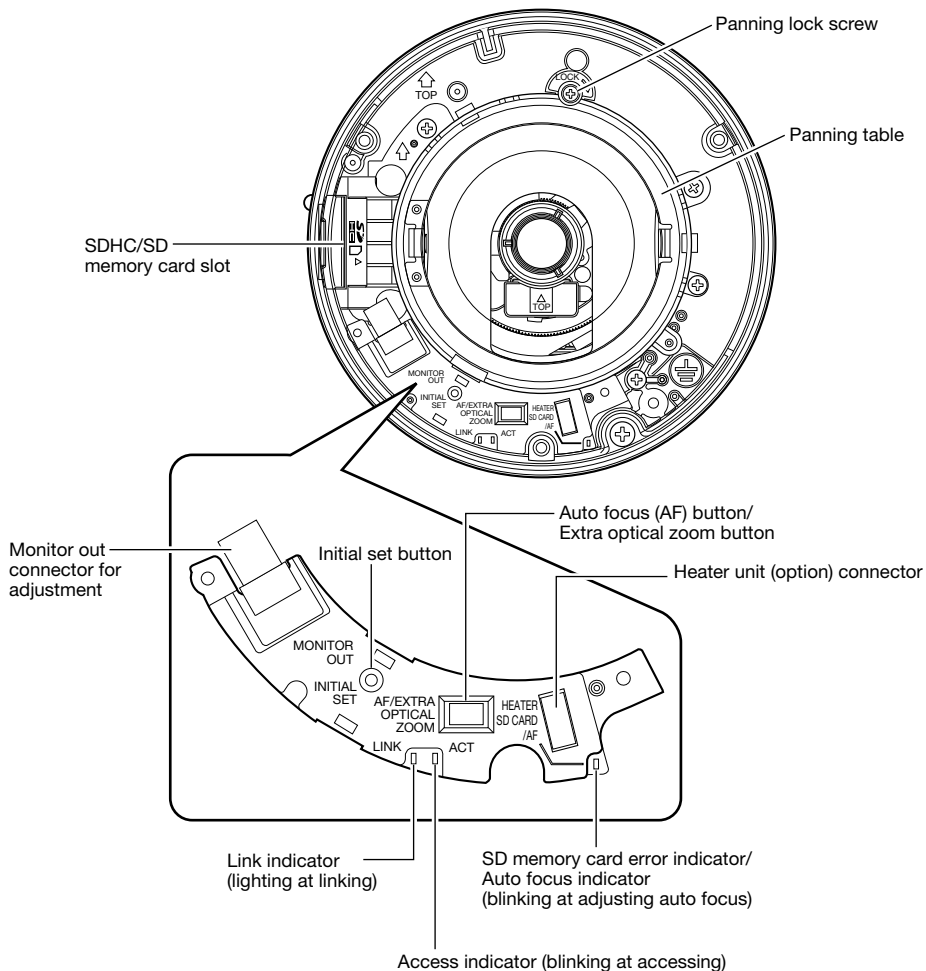

About the initial set button

After turning off the power of the camera, turn on the power of the camera while holding down this button, and wait for around 5 seconds or more without releasing the button. Wait around 2 minutes after releasing the button. The camera will start up and the settings including the network settings will be initialized. Before initializing the settings, it is recommended to write down the settings in advance. Do not turn off the power of the camera during the process of initialization. Before initializing the settings, it is recommended to copy down the settings in advance.

Preparations

When installing the camera on a wall or a ceiling, there are two methods as specified below.

- Using a two-gang junction box
- Use the supplied mount bracket

Important:

- Procure 4 screws (M4) to secure the camera attachment (accessory) or the mount bracket (accessory) to a wall or a ceiling according to the material of the installation area. Do not use wood screws and nails.

For mounting a camera on a concrete ceiling, use an anchor bolt (for M4) or an AY plug bolt (M4) for securing.

(Recommended tightening torque M4: 1.6 N·m {1.18 lbf·ft})

- Mount the camera attachment in consideration of the camera angle in accordance with the instructions (pages 19 and 20).
 - Required pull-out capacity of a single screw/bolt is 196 N {44.06 lbf} or more.
 - If a ceiling board such as plaster board is too weak to support the total weight, the area shall be sufficiently reinforced.
-

The mounting conditions of the camera are described as follows:

Installation place	Appropriate mount bracket	Recommended screw	Number of screw	Minimum pull-out strength (per 1 pc.)
Ceiling/wall	Two-gang junction box	M4	4 pcs.	196 N {44.06 lbf}
Ceiling/wall*	Mount bracket (accessory) (Approx. 350 g {0.77 lbs.})	M4	4 pcs.	196 N {44.06 lbf}

* The conditions for securing the mount bracket to a wall or a ceiling are described here.

Using a two-gang junction box

- Secure the camera attachment (accessory) to the two-gang junction box built in a wall or ceiling.

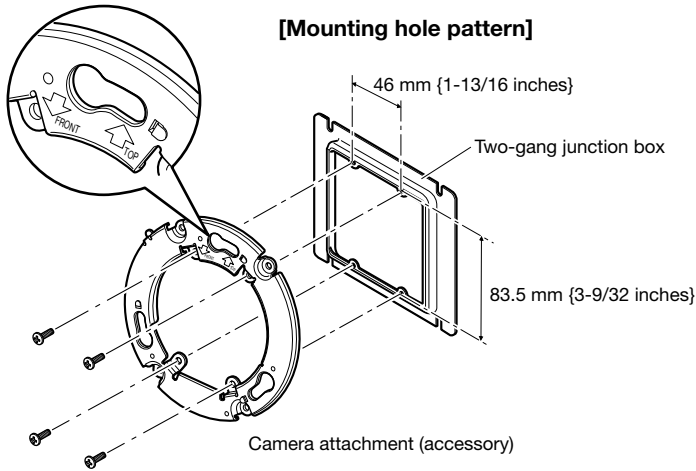

Note:

- For wall mounting:
The camera attachment shall be mounted with "↑TOP" facing upward.
 - For ceiling mounting:
The camera attachment shall be mounted with "↓FRONT" facing in the direction of the camera front (model number indication face).
-

Using the mount bracket (accessory)

Note:

- When the camera is mounted on the wall or ceiling with a hole for cable running, or the camera is mounted using open wiring, the mount bracket is used.
 - The female thread for conduit is compliant with ANSI NPSM (parallel pipe threads) 3/4 inch or G3/4 of ISO 228-1.
The female thread for conduit can be removed using a hexagon wrench.
-

Important:

- If open wiring is conducted, be sure to use conduits and run the cables inside the tubes to protect the cables from direct sunlight.
- When connecting the conduit at the lateral or bottom position, any of the arrow marks on the bracket shall be at the top.
- When connecting the conduit upward, mount the camera attachment with the arrow position on either left or right side.

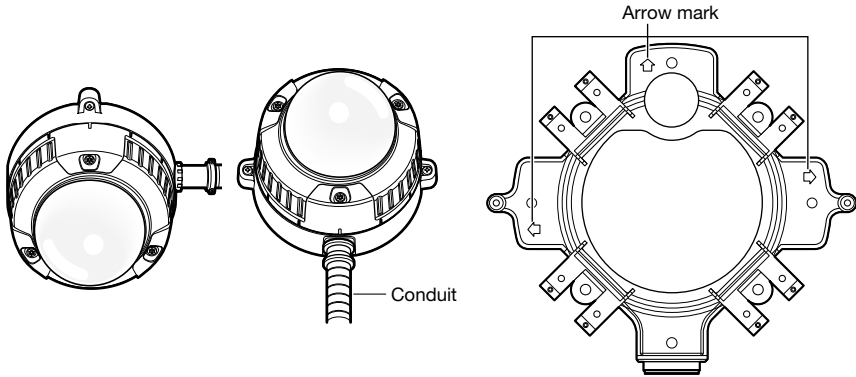
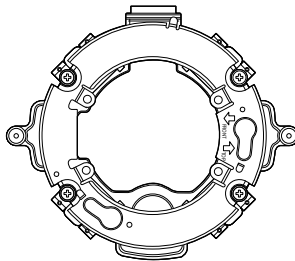
<When connecting the conduit sideward or downward>**<When connecting the conduit upward>**

- For installations on the wall, to prevent water from accumulating on the surface of the dehumidifying device (☞ page 13), do not connect it at the upper side. If water remains inside, the dehumidifying device cannot function properly.
 - Installation work shall be such that there is no intrusion of water into the architecture through the conduits having been joined.
-

- 1** Loosen two fixing screws on both ends of the base cover by using the bit for tamperproof screw (accessory), and remove the base cover (accessory).
 Install the mount bracket (accessory) on the wall/ceiling.
 (For use of the hole **A**)

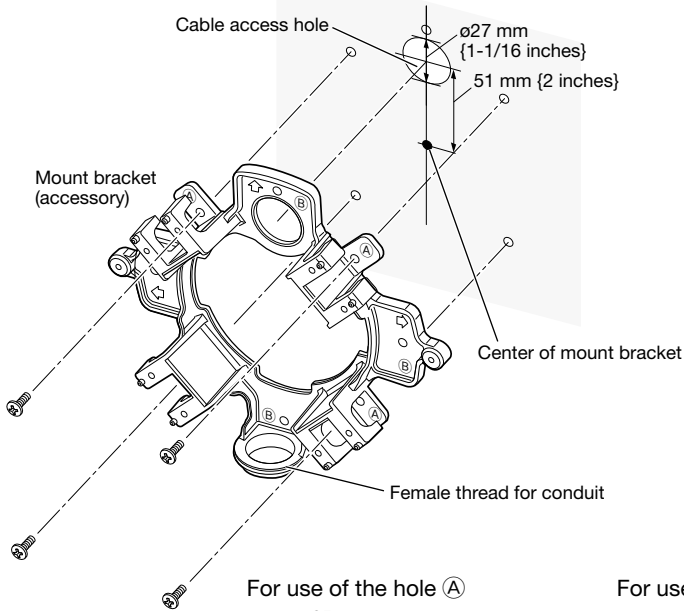
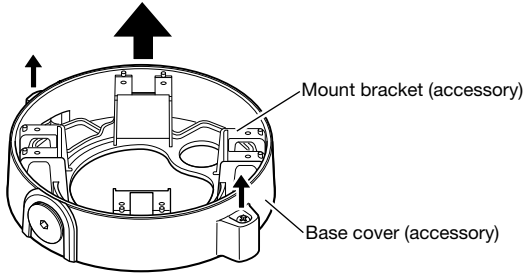

For use of the hole **A**

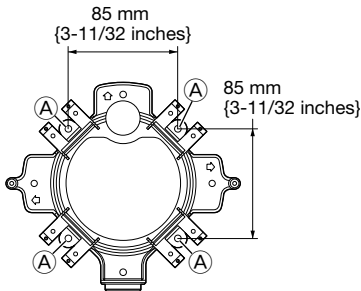

For use of the hole **B**

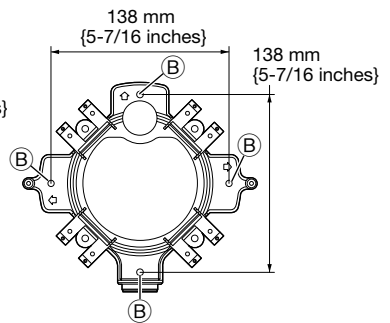

Note:

- Only the same type of holes, (A) or (B), shall be used for mounting.

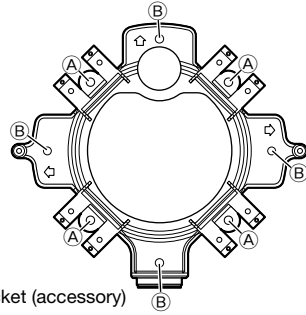

Mount bracket (accessory)

- 2 Pass the cables through the hole for cable running from the wall or ceiling.
- 3 Fix the camera attachment on the mount bracket using the screws supplied with the bracket. Recommended tightening torque: 0.78 N·m {0.58 lbf·ft}

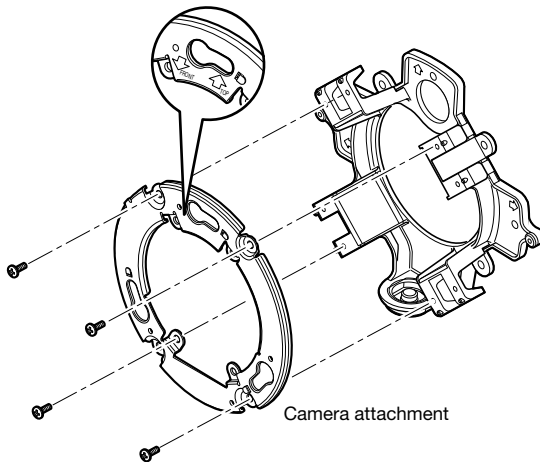

Camera attachment

Note:

- For wall mounting:
The camera attachment shall be mounted with "↑TOP" facing upward. (Except the case of connecting the conduit upward (☞ page 20))
 - For ceiling mounting:
The camera attachment shall be mounted with aligning the front side (model number indication face) of the camera with the position of the arrow in "↓FRONT".
 - Ensure that any of the arrows on the mount bracket is aligned with the "↑TOP" arrow on the camera attachment.
-

Insert/remove an SDHC/SD memory card

Important:

- Before inserting the SDHC/SD memory card, turn off the power of the camera first.
- When inserting an SDHC/SD memory card, make sure the direction.
- Before removing the SDHC/SD memory card, select "Not use" for "SD memory card" on the [SD memory card] tab of the setup menu first. Turn off the power after "Not use" selection, and then unload the SDHC/SD memory card. When the SDHC/SD memory card is inserted or removed with the power on, data in the SDHC/SD memory card may be damaged. (☞ Operating Instructions (PDF))

1 Detach the enclosure. (☞ Page 34)

2 Insert an SDHC/SD memory card fully into the SDHC/SD memory card slot until a click is heard.

3 Attach the enclosure to the camera. (☞ Page 40)

4 When removing the SDHC/SD memory card from the SDHC/SD memory card slot, detach the enclosure (☞ page 34), and push the card until a click is heard. After the SDHC/SD memory card is removed, attach the enclosure to the camera again. (☞ Page 40)

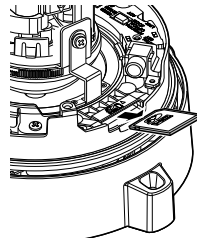
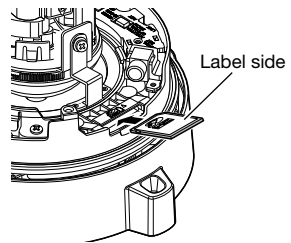

How to install the heater unit

Heater Unit WV-SW3H (option)

- Installing this heater unit enables the camera to operate in a low-temperature environment of $-30\text{ }^{\circ}\text{C}$ $\{-22\text{ }^{\circ}\text{F}\}$ or above. A small fan inside the unit will minimize condensation on the surface of the enclosure caused by changes in ambient temperature unless temperatures change too rapidly. The fan will stop when there is no possibility of condensation.
- The heater unit is automatically turned on or off according to the temperature inside the camera that is monitored.

Important:

- Turning the heater on and off may disturb the camera images.
 - The power supply of the camera shall be turned off when mounting or dismounting the heater. When servicing, pay attention to high temperature on the surface of the heater unit. Disconnect the harness and wait until the heater unit cools.
 - When this product is installed and operated in low temperatures below $-10\text{ }^{\circ}\text{C}$ $\{14\text{ }^{\circ}\text{F}\}$, normal images may not be obtained immediately after startup. In such a case, wait until the camera is warmed up (approx. 2 hours or more) and turn on the power again.
-

How to install the heater unit

- ① Detach the camera's enclosure (☞ page 34) and mount it in the specified position with the screw (accessory).
- ② Connect the harness cable to the heater unit connector of the camera.

Important:

- After mounting the heater unit, arrange the harness cable as shown in the illustration in step ③ so as not to be tangled round the enclosure, assist wire or equipment inside the camera.
-

③ Attach the enclosure to the camera. (☞ Page 40)

Heater unit
(option) connector

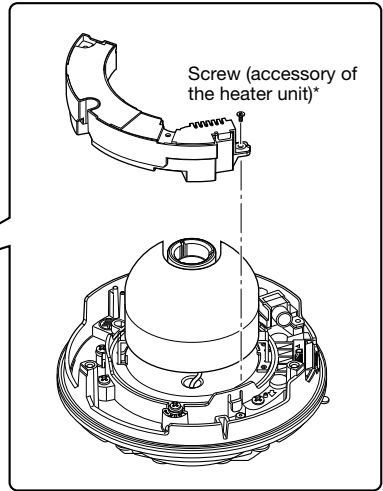
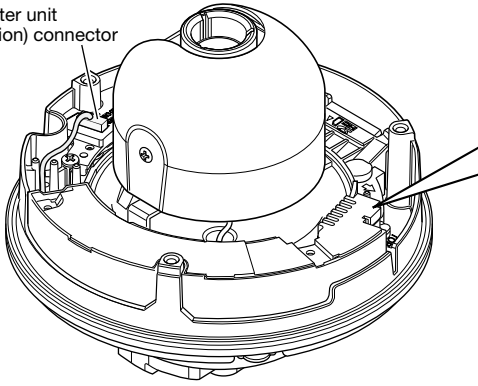

* Two screws are supplied with the heater unit.
(Of them, 1 for spare)

Connection

Caution:

- FOR UL LISTED MODEL(S), ONLY CONNECT 12 V DC CLASS 2 POWER SUPPLY.

Turn off a circuit breaker before making a connection. Before starting the connection, prepare the required devices and cables.

Note:

- When using the mount bracket (accessory), it is possible to connect the cables after mounting the camera onto the mount bracket.
- Refer to page 20 when connecting the conduit.

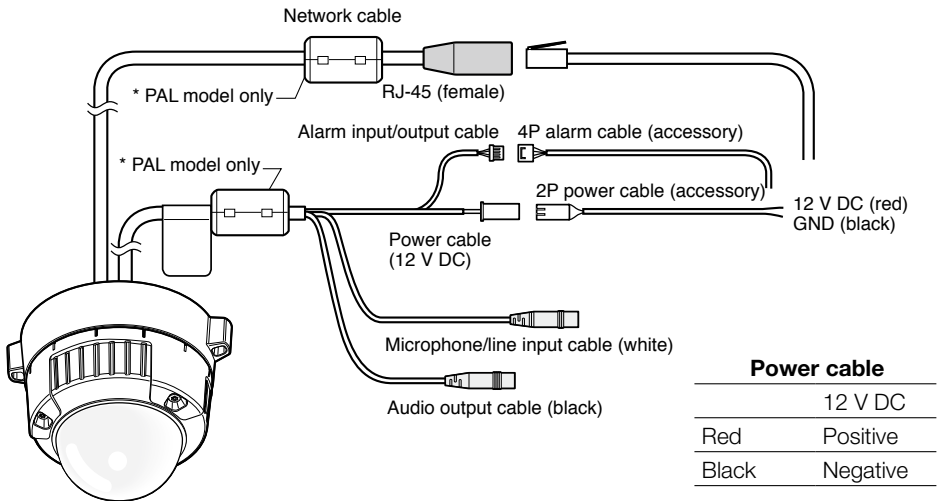

- 1 Connect the microphone/line input cable and the microphone (for use of the audio reception function).

Input impedance: $2\text{ k}\Omega \pm 10\%$

Recommended cable length: Less than 1 m {3.28'} (for microphone input)
Less than 10 m {32.8'} (for line input)

Recommended microphone: Plug-in power type microphone (option)
Connect a mini plug ($\phi 3.5\text{ mm}$).

Supply voltage: $2.5\text{ V} \pm 0.5\text{ V}$

Recommended sensitivity of microphone: $-48\text{ dB} \pm 3\text{ dB}$ (0 dB=1 V/Pa, 1 kHz)

Important:

- Connect/disconnect the external speaker cables or audio/video cables after turning off the power of the camera and the amplifier. Otherwise, loud noise may come out from the speaker.

- 2** Connect an external amplifier-embedded speaker to the audio output cable (for use of the audio transmission function).
 Connect a stereo mini plug (ø3.5 mm) (Audio output is monaural.).
- Recommended cable length: Less than 10 m {32.8 ft}

- 3** Connect the alarm input/output cable.

<Ratings>

Terminal name	Ratings
ALARM OUT, AUX OUT	Open collector output (maximum applied voltage: 20 V DC)
Open	4 V DC - 5 V DC by internal pull-up
Close	Output voltage 1 V DC or less (50 mA or less)
ALARM IN, DAY/NIGHT IN	Non-voltage make contact input (4 V DC - 5 V DC, internally pulled up)
OFF	Open or 4 V DC - 5 V DC
ON	Make contact with GND (required drive current: 1 mA or more)

Note:

- Check if rating of an external device such as a sensor is applicable to the rating of this product by referring to the provided operating instructions.

Specification of 4P alarm cable (accessory)

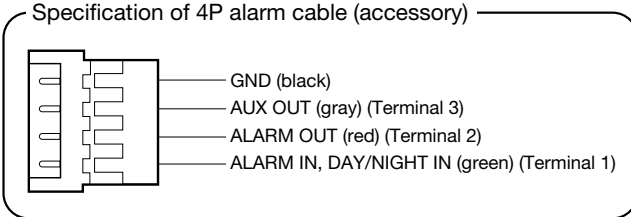

4 Connect a LAN cable (category 5e or better, straight, STP*) to the network connector.
* PAL model only

5 Connect the power cable.

- **When using 12 V DC power supply*¹**

Connect the output cable of the AC adaptor to the 2P power cable.

- **When using PoE (IEEE802.3af compliant)**

Connect a LAN cable (category 5 or better, straight, STP*²) between a PoE device (such as a hub) and the network connector of the camera.

*1 FOR UL LISTED MODEL(S), ONLY CONNECT 12 V DC CLASS 2 POWER SUPPLY.

*2 PAL model only

Important:

- Use all 4 pairs (8 pins) of the LAN cable.
 - The maximum cable length is 100 m {328 feet}.
 - Make sure that the PoE device in use is compliant with IEEE802.3af standard.
 - When connecting both the 12 V DC power supply and the PoE device for power supply, PoE will be used for power supply.
 - When the LAN cable is disconnected once, reconnect the cable after about 2 seconds. When the cable is quickly reconnected, the power may not be supplied from the PoE device.
-

Waterproof treatment for the cable joint sections

Adequate waterproof treatment is required for the cables when installing the camera with cables exposed or installing it under the eaves. The camera body is waterproof, but the cable ends are not waterproof.

Be sure to use the supplied butyl rubber tape at the points where the cables are connected to apply waterproof treatment in the following procedure. Failure to observe this or use of a tape other than the provided butyl rubber tape (such as a vinyl tape) may cause water leakage resulting in malfunction.

LAN cable

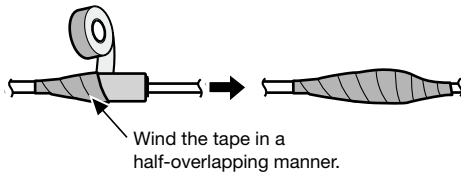

Alarm input/output cable, power cable, microphone/line input cable, audio output cable

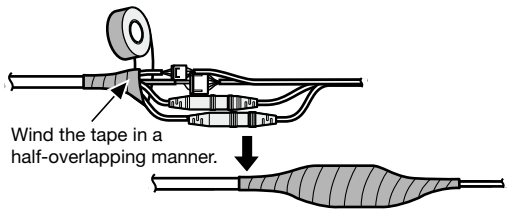

Important:

- Waterproof treatment is also to be applied to the 2P power cable (accessory), the 4P alarm cable (accessory) and other connection cables if they are subject to rain.
-

Note:

- How to wind the supplied waterproof butyl tape
Stretch the tape by approx. twice (see the illustration) and wind it around the cable. Insufficient tape stretch causes insufficient waterproofing.
- To install this product outdoors, be sure to waterproof the cables. Waterproof grade (IEC IP66 or equivalent) is applied to this product only when it is installed correctly as described in these operating instructions and appropriate waterproof treatment is applied. The mount brackets are not waterproofed.

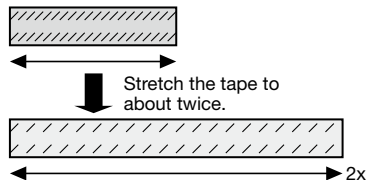

Connection example when connecting to a network using a PoE hub

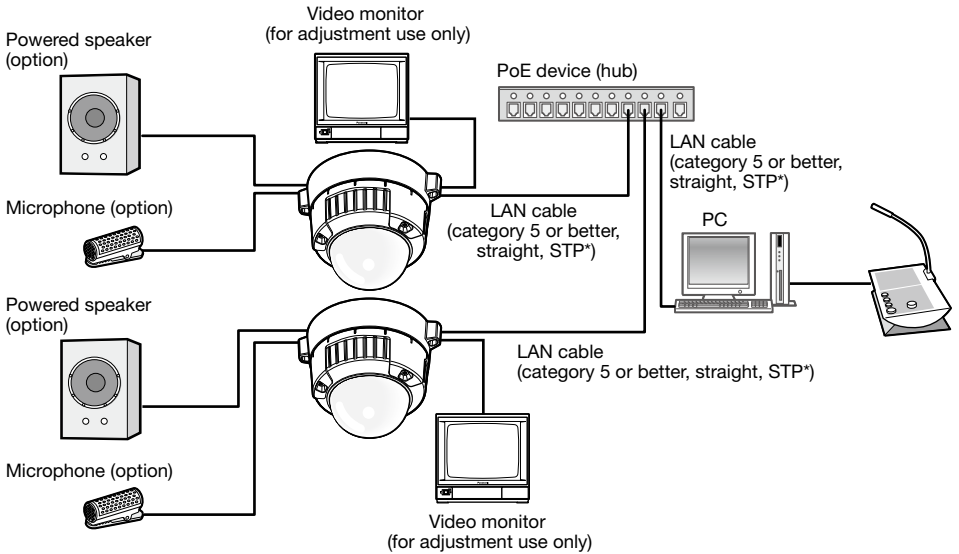

<Required cable>

LAN cable (category 5 or better, straight, STP*)

* PAL model only

Important:

- The video monitor is used for checking the adjustment of the angular field of view when installing the camera or when servicing. It is not provided for recording/monitoring use.
 - Use a switching hub or a router which is compliant with 10BASE-T/100BASE-TX.
 - Power supply is required for each network camera. When using a PoE device (hub), 12 V DC power supply is unnecessary.
-

Installation

1 Mount the camera.

<Using a two-gang junction box>

- ① Connect each cable. (☞ Page 26) Waterproof the connecting portion. (☞ Page 29)
- ② Align the "OPEN" on the camera with the projection of the camera attachment.
- ③ Engage the camera attachment fixing screws on the rear of the camera in the camera mounting holes of the camera attachment and rotate the camera in the arrow direction to secure the camera attachment and camera.

Rotate the camera until a click is heard so that the projection of the camera attachment will be set to the "LOCK" position.

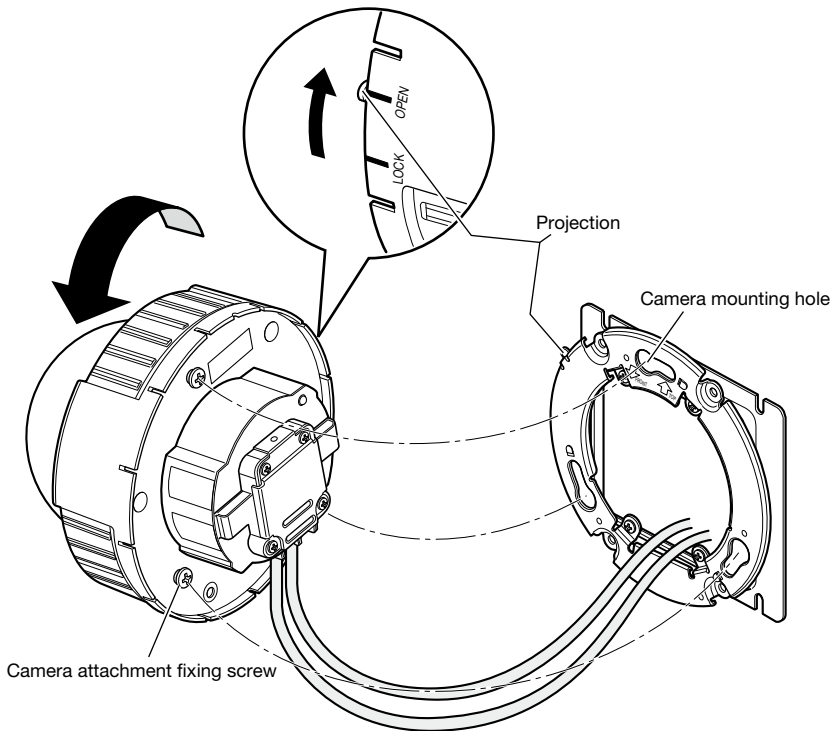

<Using the mount bracket>

- ① Attach the camera onto the camera attachment while aligning the "OPEN" mark of the camera with the projection of the camera attachment.

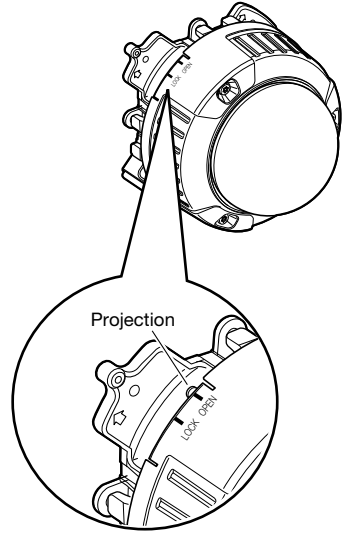
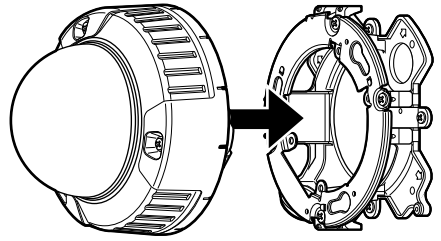

Important:

- When mounting the camera body, cables shall be run between the camera attachment and mount bracket as indicated by the arrows in the illustration.
- * Cable running as indicated by the arrows in the illustration is an example. Cable running shall be varied with installation environment.

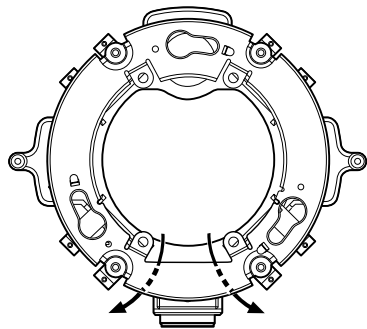

- ② Engage the rear-side screw of the camera with the screw hole of the camera attachment and rotate the camera in the direction of the arrow to secure the camera to the camera attachment.

Rotate the camera until a click is heard so that the projection of the camera attachment will be set to the "LOCK" position.

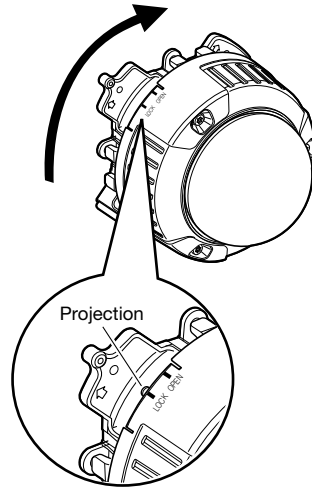

- ③ Connect the cables on the side of the mount bracket. (☞ Page 26)

Waterproof the connecting portion. (☞ Page 29)

Note:

- Disconnect the 12 V power source and PoE power source to prevent power from being supplied during mounting work.
-

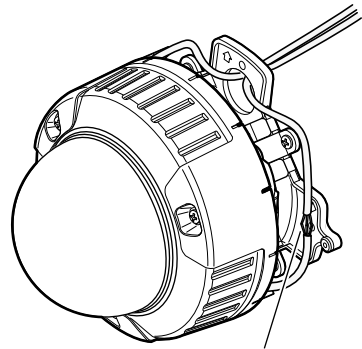

Make cable connection and waterproof the connected section.

- ④ Accommodate the connected cables inside the cable guide of the camera mount bracket.

Important:

- To prevent the cables from being caught when the base cover is attached, keep the cables inside the cable guide.
-

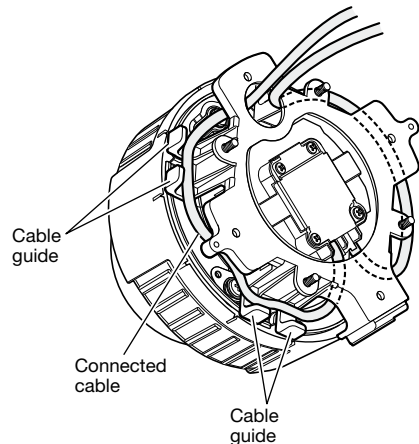

- ⑤ Attach the base cover that was removed according the steps in page 21.

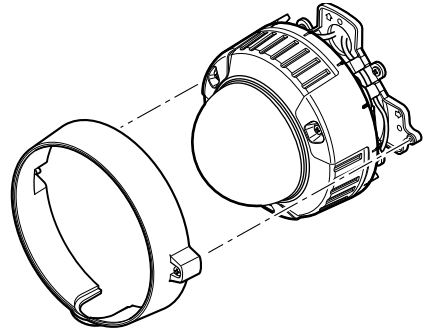

Base cover

- ⑥ Use the bit for tamperproof screw (accessory) to tighten the fixing screws provided on both sides of the base cover. (Recommended tightening torque: 0.78 N·m {0.58 lbf-ft})

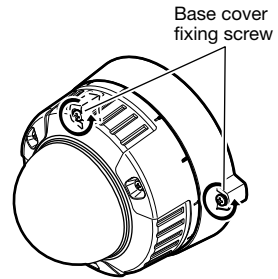

Base cover fixing screw

- 2 Detach the enclosure and inner dome from the main body by loosening the three fixing screws. Loosen the three fixing screws by using the bit for tamperproof screw (accessory). Detach the inner dome while pushing toward the directions as indicated by the arrows in the illustration.

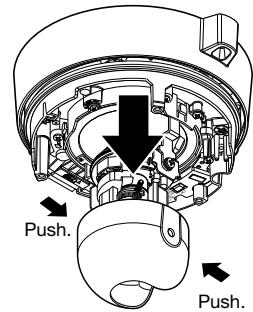

Push.

Push.

Important:

- Do not hold the inner dome when carrying the camera. Otherwise, the camera part may fall and it may damage the camera.
 - Remove the cover film from the transparent part of the dome cover after the installation is complete. Do not touch the dome cover by hand directly after removing the cover film.
-

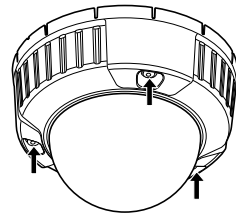

- 3** Secure the camera to the mount bracket with the camera fixing screw (red, 1 position).
The illustration is an example of using the mount bracket (accessory).

Important:

- Be sure to tighten the camera fixing screw. Failure to observe this may cause camera trouble due to water leakage or camera falling. (Recommended tightening torque: 0.78 N·m {0.58 lbf·ft})
-

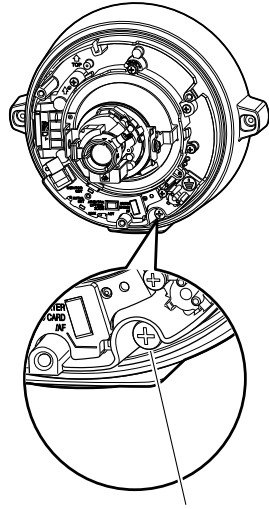

Camera fixing screw (red)

* The camera fixing screw shall be securely tightened.

Adjustment

1 Adjust the camera angle.

When determining the camera angle, repeat fine adjustments by gradually moving the panning table, tilting table, and azimuth adjustment ring.

Horizontal position (Panning)

Loosen the panning lock screw, rotate the panning table to adjust the pan direction. (Adjustable range: 340 °)

Panning is possible within the range of 180 ° (when panning clockwise) and 160 ° (when panning counterclockwise).

After adjustment, tighten the panning lock screw to fix the panning table.

(Recommended tightening torque: 0.59 N·m {0.44 lbf·ft})

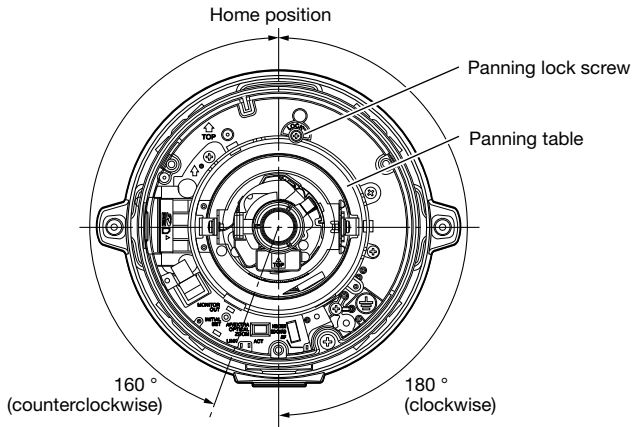

Vertical position (Tilting)

Loosen the tilting lock screws (x2), and rotate the tilting table to adjust the tilting direction. (Adjustable range: $\pm 75^\circ$) Since a variable focal lens is used, it is possible to change the angular field of view. This lens can also be rotated in the reverse direction, but the image azimuth is reversed. In this case, the image azimuth can be modified when the panning table is rotated to the direction of clockwise panning (180 °).

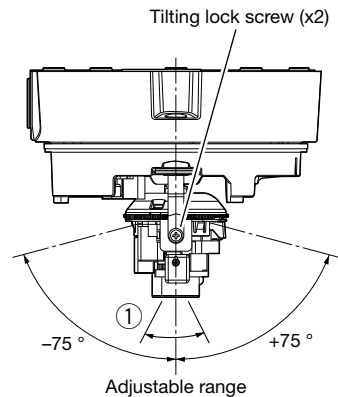

<Lens angular field of view (① Angle)>

Horizontal: 27.7 ° (TELE) to 100.8 ° (WIDE)

Vertical: 20.8 ° (TELE) to 73.8 ° (WIDE)

After adjustment, tighten the tilting lock screws (x2) to fix the tilting table.

(Recommended tightening torque: 0.59 N·m {0.44 lbf·ft})

Note:

- When the tilting table is turned to the edge of the adjustable range ($\pm 75^\circ$), it must be noted that the shadow of the enclosure may be projected.
-

Image tilt adjustment

Rotate the azimuth adjustment ring to adjust the azimuth angle of the image. (Adjustable range: $\pm 100^\circ$)

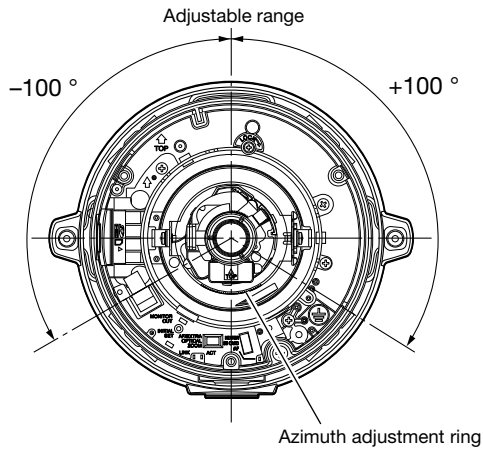

2 Adjust the angular field of view and the focus.

Adjust the angular field of view in accordance with the distance between the camera lens and a photographic subject. These adjustments shall be performed together with the camera angle adjustment.

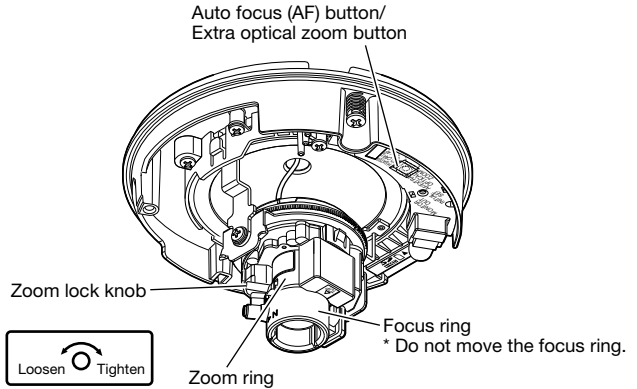
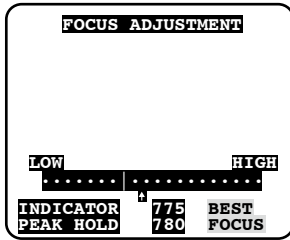

- ① Loosen the zoom lock knob and move the knob between TELE and WIDE to obtain the appropriate angle of view.

Note:

- The focus may not be adjusted appropriately when the zoom ring is positioned at the "W" (or "T") end. In this case, adjust the focus again by slightly moving the zoom ring to the direction of "T" (or "W").
-
- ② To adjust the angular field of view with a higher zooming effect even after rotating the zoom ring almost fully in the "T" direction, hold down the auto focus (AF) button/extra optical zoom button for 5 seconds or more. 2x extra optical zoom will be applied. When the image capture size under "VGA" is applied, the zoom factor can be adjusted up to 2x without deterioration of image quality. When holding down the auto focus (AF) button/extra optical zoom button again for 5 seconds or more, 1x extra optical zoom will be applied.
 - ③ Tighten the zoom lock knob.
 - ④ When the auto focus (AF) button is pressed, the auto focus (AF) indicator will light for around 10 seconds, and the focus is automatically adjusted.

Important:

- Do not move the focus ring.
 - Defocus may be caused by the reinstalled enclosure. In this case, perform the auto focus function from the setup menu.
-

Note:

- If the zoom ring is fully rotated in the "W" direction, the periphery may become dark. In such a case, rotate the zoom ring in the "T" direction for readjustment.
 - If the zoom lock knob is slightly tightened before the zoom ring is moved, the ring will become stable to ease the fine adjustment.
 - When shooting in the following place or the following subjects, focus may not be adjusted automatically. In this case, adjust the focus manually from the setup menu. Refer to the Operating Instructions (PDF) for how to perform the manual focus adjustment from the setup menu.
 - Subj. moving frequently
 - Subj. with large illuminance change
 - Subj. with low illuminance
 - Subj. with reflection or extra brightness
 - Subj. through a window
 - Place where the dome cover easily becomes dirty
 - Subj. with less contrast such as white wall
 - Subj. with heavy flicker
 - If the 2x extra optical zoom is applied when "1280x960", "1280x720" (SW355) or "800x600" (SW352) is selected for the image capture size, the image quality will be deteriorated because the effect of Extra Optical Zoom is not provided.
 - When images in the near-infrared light area change from color to black & white, out-of-focus may be occurred according to the nature of optical property. In this case, the focus can automatically be corrected by selecting "Auto" or "Preset" for "Adjusting method" on the setup menu (The focus will not automatically be adjusted according to the illumination level change once the focus is corrected.) Refer to the Operating Instructions (PDF) for how to set "Adjusting method" on the setup menu.
-

3 Mount the inner dome that was removed according the steps in page 34 in the reverse procedure. Check to see that the tilting lock screws of the camera are properly engaged in the holes of the inner dome.

Tighten the screws that have been loosened in step **2** on page 34 using the bit for tamper-proof screw (accessory).

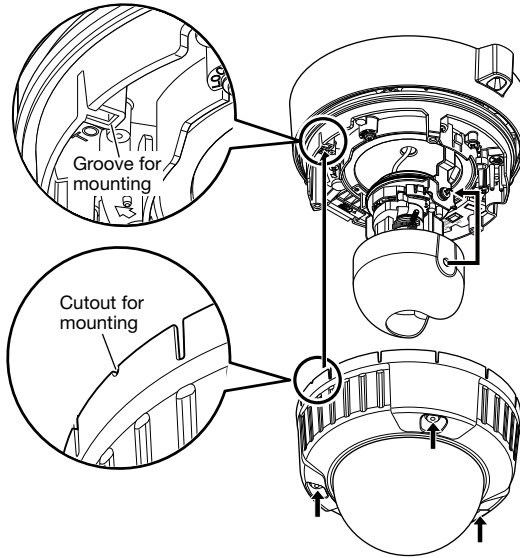

Important:

- Securely tighten all the fixing screws (x3) of enclosure. Otherwise, water exposure may cause damage or malfunction of camera, or camera dropping may result in injury. (Recommended tightening torque: 0.78 N·m {0.58 lbf·ft})
 - Attach the inner dome in accordance with the direction of the lens opening not to change the lens direction.
 - Check if the inner dome and tilting lock screws are firmly fit.
 - Remove the protection sheet from the outside of the dome.
-

Configure the network settings

Install the software

Before installing the software, refer to the readme file on the provided CD-ROM first.

Software included on the provided CD-ROM

- Panasonic IP setting software
Configure the network settings of the camera. Refer to the following for further information.
- Viewer Software "Network Camera View 4S"
It is necessary to install the viewer software "Network Camera View 4S" to display images on a PC. Install the viewer software by double-clicking the "nwcvc4Ssetup.exe" icon on the provided CD-ROM.

Configure the network settings of the camera using the Panasonic IP setting software

It is possible to perform the network settings of the camera using the IP setup software on the provided CD-ROM.

When using multiple cameras, it is necessary to configure the network settings of each camera independently.

If the Panasonic IP setting software does not work, configure the network settings of the camera and the PC individually on the "Network" page of the setup menu. Refer to the Operating Instructions (PDF) for further information.

Important:

- When using Microsoft Windows 7 or Microsoft Windows Vista, the "Windows Security Alert" window may be displayed when starting the IP setup software. In this case, disable "User Account Control" from the control panel.
 - For the security enhancement, the MAC address/IP address of the camera to be configured will not be displayed when around 20 minutes have passed after turning on the power of the camera. (When the effective period is set to "20min" in the IP setup)
 - Panasonic IP setting software is inoperable in other subnets via the same router.
 - This camera cannot be displayed or set with an older version of the IP setup software (version 2.xx).
-

- 1 Start the Panasonic IP setting software by double-clicking the "EasyIpSetup.exe" icon on the provided CD-ROM.
The License Agreement will be displayed. Read the Agreement and choose "I accept the term in the license agreement", and click "OK".

- 2 Click the [Network Settings] button after selecting the MAC address/IP address of the camera to be configured.

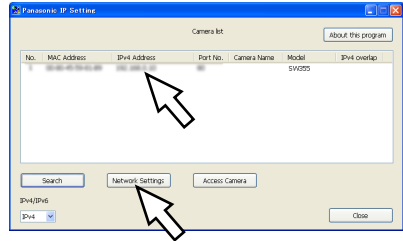

Note:

- When using a DHCP server, the IP address assigned to the camera can be displayed by clicking the [Search] button of the IP setting software.
 - When a duplicate IP address is used, the corresponding camera number will be displayed shaded.
 - When the [Access Camera] button is clicked, live images of the selected camera will be displayed.
 - It is possible to change the "Camera list" display between IPv4 addresses and IPv6 addresses in accordance with the protocol in use.
-

- 3 Complete each network setup item and click the [Save] button.

Note:

- When selecting "DHCP" or "AutoIP", it is possible to set "DNS" to "Auto".
-

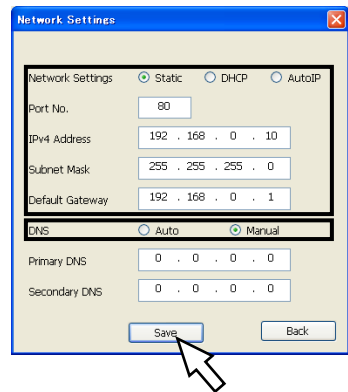

Important:

- It may take for around 2 minutes to complete to upload the settings to the camera after clicking the [Save] button. The settings may be invalidated when the 12 V DC power supply is cut or when the AC adaptor or the LAN cable is disconnected before completing the upload. In this case, perform the settings again.
 - When using a firewall (including software), allow access to all UDP ports.
-

Troubleshooting

Before asking for repairs, check the symptoms with the following table.

Contact your dealer if a problem cannot be solved even after checking and trying the solution in the table or a problem is not described below.

Symptom	Cause/solution	Reference pages
Power is not turned on.	<p>When using DC power supply</p> <ul style="list-style-type: none">• Is DC 12 V power supply connected to the 2P power supply cable? → Check whether the connection is appropriately established.• Is the AC adaptor in use compliant with the Specifications? → Check the Specifications regarding AC adaptor. <p>When using a PoE device for power supply</p> <ul style="list-style-type: none">• Are the PoE device and the network cable of the camera connected using a LAN cable? → Check whether the connection is appropriately established.• Depending on the PoE device, the power supply will stop when the demanded power exceeds its total power limit for all PoE ports. → Refer to the operating instructions of the PoE device in use.	26

Specifications

• Basic

Power source:	12 V DC, PoE (IEEE802.3af compliant)
Power consumption:	12 V DC*: 300 mA, PoE 48 V: 80 mA (Class 0 device)
(With heater):	12 V DC*: 1.1 A, PoE 48 V: 240 mA (Class 0 device)
	* FOR UL LISTED MODEL(S), ONLY CONNECT 12 V DC CLASS 2 POWER SUPPLY.
Ambient operating temperature:	-10 °C to +50 °C {14 °F to 122 °F}
(With heater):	-30 °C to +50 °C {-22 °F to 122 °F}
Ambient operating humidity:	Less than 90 % (no condensation)
Waterproof:	Camera: IP66 (IEC60529)
	* Only when installation work specified in this book is properly performed and appropriate waterproof treatment is performed
Shock resistance:	Compliant with 50 J IEC 60068-2-75/IEC 62262 IK10
Monitor output (for adjusting the angular field of view):	VBS: 1.0 V [p-p]/75 Ω, composite signal, RCA jack
EXT I/O terminal cable:	ALARM IN, DAY/NIGHT IN, ALARM OUT, AUX OUT (x1 for each)
Microphone/line input cable:	ø3.5 mm monaural mini jack
	Input impedance: Approx. 2 kΩ
For microphone input:	Applicable microphone: Plug-in power type
	Supply voltage: 2.5 V ±0.5 V
For line input:	Input level: Approx. -10 dBV
Audio output cable:	ø3.5 mm stereo mini jack (monaural output)
	Output impedance: Approx. 600 Ω
	Line level
Dimensions:	ø164 mm x 146 (H) mm x 191.5 (W) mm
	{ø6-15/32 inches x 5-3/4 inches (H) x 7-17/32 inches (W)}
	(including projection of the base cover fixing screw)
Mass:	Approx. 1.6 kg {3.53 lbs}
Finish:	Main body: Aluminum die cast, light gray
	Dome section: Clear polycarbonate resin

• Camera

Image sensor:	1/3-type MOS image sensor
Effective pixels:	Approx. 1.3 megapixels
Scanning area:	4.80 mm (H) × 3.60 mm(V) {3/16 inches (H) x 5/32 inches (V)}
Scanning system:	Progressive
Minimum illumination SW355 :	Color: 0.3 lx {0.03 footcandle}
	(F1.6, Auto slow shutter: Off (1/30 s), Gain: On(High))
	0.019 lx {0.0019 footcandle}
	(F1.6, Auto slow shutter: max. 16/30 s, Gain: On(High))*
	BW: 0.05 lx {0.005 footcandle}
	(F1.6, Auto slow shutter: Off (1/30 s), Gain: On(High))
	0.003 lx {0.0003 footcandle}
	(F1.6, Auto slow shutter: max. 16/30 s, Gain: On(High))*
Minimum illumination SW352 :	Color: 0.2 lx {0.02 footcandle}
	(F1.6, Auto slow shutter: Off (1/30 s), Gain: On(High))
	0.013 lx {0.0013 footcandle}
	(F1.6, Auto slow shutter: max. 16/30 s, Gain: On(High))*

BW: 0.04 lx {0.004 footcandle}
(F1.6, Auto slow shutter: Off (1/30 s), Gain: On(High))
0.002 lx {0.0002 footcandle}
(F1.6, Auto slow shutter: max. 16/30 s, AGC: High)*

* Converted value

Super-Dynamic: On/Off
Dynamic range: 52 dB typ. (Super-Dynamic: On, light control: indoor scene)
Gain (AGC): On(Low)/ On(Mid)/ On(High)/ Off
Adaptive black stretch: On/Off
Light control mode setting: Indoor scene (50 Hz/60 Hz)/ Outdoor scene/ Fix shutter
Shutter speed: 1/30, 3/100, 3/120, 2/100, 2/120, 1/100, 1/120, 1/250, 1/500,
1/1000, 1/2000, 1/4000, 1/10000 (only at Super-Dynamic Off)
Auto slow shutter: Off (1/30 s), max. 2/30 s, max. 4/30 s, max. 6/30 s,
max. 10/30 s, max. 16/30 s
Color/BW: On/ Off/ AUTO1/ AUTO2
White balance: ATW1/ ATW2/ AWC
Digital noise reduction: High/Low
Video analytics
Face detection: On/Off (with the XML notification setting)
Privacy zone: On/Off (up to 2 zones available)
VIQS: On/Off
Camera title on screen: Up to 20 characters (alphanumeric characters, marks)
Video motion detection (VMD alarm): On/Off, 4 areas available

• Lens

Zoom ratio: 3.6x
Extra zoom: 7.2x (under VGA resolution)
Focal length: 2.8 mm - 10 mm
Maximum aperture ratio: 1:1.6 (WIDE) - 1:3.6 (TELE)
Angular field of view: Horizontal: 27.7 ° (TELE) - 100.8 ° (WIDE)
Vertical: 20.8 ° (TELE) - 73.8 ° (WIDE)
Adjusting angle: Horizontal: 180 ° (clockwise), 160 ° (counterclockwise)
Vertical: ±75 °
Image tilt adjustment range: ±100 °

• Network

Network: 10BASE-T/100BASE-TX, RJ45 connector
Resolution **SW355** : Aspect ratio: 4:3
H.264 1280×960/ VGA (640×480)/
QVGA (320×240), max. 30 fps
MPEG-4 VGA (640×480)/ QVGA (320×240),
max. 30 fps
JPEG (MJPEG) 1280×960/ VGA (640×480)/
QVGA (320×240), max. 30 fps
Aspect ratio: 16:9
H.264 1280×720/ 640×360/ 320×180, max. 30 fps
JPEG (MJPEG) 1280×720/ 640×360/ 320×180, max. 30 fps
* MPEG-4 is not supported.
Resolution **SW352** : Aspect ratio: 4:3
H.264 800×600/ VGA (640×480)/ QVGA (320×240),
max. 30 fps

	MPEG-4	VGA (640×480)/ QVGA (320×240), max. 30 fps
	JPEG (MJPEG)	800×600/ VGA (640×480)/ QVGA (320×240), max. 30 fps
	Aspect ratio:	16:9
	H.264	640×360/ 320×180, max. 30 fps
	JPEG (MJPEG)	640×360/ 320×180, max. 30 fps
	* MPEG-4 is not supported.	
Image compression method* ¹ * ² :	H.264/MPEG4	
	Image quality: Low/ Normal/ Fine	
	Transmission type: Unicast/Multicast	
	Audio bit rate:	
	Constant bit rate/Best effort: 64 kbps/ 128 kbps/ 256 kbps/ 384 kbps/ 512 kbps/ 768 kbps/ 1024 kbps/ 1536 kbps/ 2048 kbps/ 3072 kbps/ 4096 kbps/ *8192 kbps	
	* only in H.264 mode SW355	
	Frame rate:	
	1 fps/ 3 fps/ 5 fps/ 7.5 fps/ 10 fps/ 12 fps*/ 15 fps/ 20 fps/ 30 fps	
	* PAL model only	
	JPEG (MJPEG)	
	Image quality:	
	0 SUPER FINE/ 1 FINE/ 2/ 3/ 4/ 5 NORMAL/ 6/ 7/ 8/ 9 LOW (10 steps: 0-9)	
	Transmission type: PULL/PUSH	
Transmission interval:	0.1 fps - 30 fps (JPEG frame rate will be restricted when displaying both JPEG and H.264/MPEG-4 images.)	
Audio compression method:	G.726 (ADPCM) 32 kbps/16 kbps	
	G.711 64 kbps	
Bandwidth control:	Unlimited/ 64 kbps/ 128 kbps/ 256 kbps/ 384 kbps/ 512 kbps/ 768 kbps/ 1024 kbps/ 2048 kbps/ 4096 kbps/ 8192 kbps SW355	
Protocol:	IPv6: TCP/IP, UDP/IP, HTTP, HTTPS, RTP, FTP, SMTP, DNS, NTP, SNMP, DHCPv6	
	IPv4: TCP/IP, UDP/IP, HTTP, HTTPS, RTSP, RTP, RTP/RTCP, FTP, SMTP, DHCP, DNS, DDNS, NTP, SNMP, UPnP	
OS* ³ * ⁴ :	Microsoft Windows 7 Professional (64-bit) Microsoft Windows 7 Professional (32-bit) Microsoft Windows Vista Business SP1 (32-bit) Microsoft Windows XP Professional SP3	
Browser:	Windows Internet Explorer 8.0 (32-bit) (Microsoft Windows 7 Professional (32-bit/64-bit)) Windows Internet Explorer 7.0 (Microsoft Windows Vista Business SP1 (32-bit)) Microsoft Internet Explorer 6.0 SP3 (Microsoft Windows XP Professional SP3)	
Maximum concurrent access number:	14 (Depends on network conditions)	
FTP client:	Alarm image transmission, FTP periodic transmission (When the FTP transmission is failed, backup on an optional SDHC/SD memory card is available.)	
Multi-screen:	Up to 16 camera images can be displayed simultaneously on a multi-screen. (Including the camera itself)	

Compatible SDHC/

SD memory card (option):

Manufactured by Panasonic

SDHC memory card: 4 GB, 8 GB, 16 GB, 32 GB

SD memory card: 256 MB, 512 MB, 1 GB, 2 GB

(except miniSD card and microSD card)

Cellular phone compatibility:

JPEG image, AUX control (by access level)

*1 Either H.264 or MPEG-4 is selectable.

*2 Transmission for 2 streams can be individually set in the same compression method.

*3 Refer to "Notes on Windows Vista® / Windows® 7" (PDF) on the provided CD-ROM for further information about system requirements for a PC and precautions when using Microsoft Windows 7 or Microsoft Windows Vista.

*4 When using IPv6 for communication, use Microsoft Windows 7 or Microsoft Windows Vista.

Standard accessories

Installation Guide (this document)	1 pc.
Warranty card (NTSC model only)	1 pc.
CD-ROM* ¹	1 pc.
Code label* ²	1 pc.

The following parts are used during installation procedures.

4P alarm cable	1 pc.
Camera attachment	1 pc.
2P power cable	1 pc.
Fixing screws (M4 x 8 mm)	5 pcs. (of them, 1 for spare)
Base cover	1 pc.
Mount bracket	1 pc.
Bit for tamperproof screw	1 pc.
Butyl tape	1 pc.

*1 The CD-ROM contains the operating instructions (PDFs) and different kinds of tool software programs.

*2 This label may be required for network management. The network administrator shall retain the code label.

Optional accessories

Ceiling mount bracket.....	WV-Q169
Smoke Dome Cover	WV-CW4S
Heater Unit	WV-SW3H
User License Accessory (For MPEG-4)	BB-HCA5A (NTSC model) BB-HCA5CE (PAL model, Korea*) * Required in Korea
User License Accessory (For H.264)	BB-HCA8A (NTSC model) BB-HCA8CE (PAL model, Korea*) * Required in Korea

Information for Users on Collection and Disposal of Old Equipment and used Batteries



These symbols on the products, packaging, and/or accompanying documents mean that used electrical and electronic products and batteries should not be mixed with general household waste.

For proper treatment, recovery and recycling of old products and used batteries, please take them to applicable collection points, in accordance with your national legislation and the Directives 2002/96/EC and 2006/66/EC.

By disposing of these products and batteries correctly, you will help to save valuable resources and prevent any potential negative effects on human health and the environment which could otherwise arise from inappropriate waste handling.

For more information about collection and recycling of old products and batteries, please contact your local municipality, your waste disposal service or the point of sale where you purchased the items.

Penalties may be applicable for incorrect disposal of this waste, in accordance with national legislation.



For business users in the European Union

If you wish to discard electrical and electronic equipment, please contact your dealer or supplier for further information.

[Information on Disposal in other Countries outside the European Union]

These symbols are only valid in the European Union. If you wish to discard these items, please contact your local authorities or dealer and ask for the correct method of disposal.



Cd

Note for the battery symbol (bottom two symbol examples):

This symbol might be used in combination with a chemical symbol. In this case it complies with the requirement set by the Directive for the chemical involved.

For U.S. and Canada:

**Panasonic System Communications
Company of North America,
Unit of Panasonic Corporation
of North America**

www.panasonic.com/business/
For customer support, call 1.800.528.6747
Three Panasonic Way, Secaucus,
New Jersey 07094 U.S.A.

Panasonic Canada Inc.

5770 Ambler Drive, Mississauga,
Ontario, L4W 2T3 Canada
(905)624-5010
www.panasonic.ca

For Europe and other countries:

Panasonic Corporation

<http://panasonic.net>

Importer's name and address to follow EU rules:

Panasonic Testing Centre
Panasonic Marketing Europe GmbH
Winsbergring 15, 22525 Hamburg F.R.Germany