

Panasonic®

Installation Guide

Included Installation Instructions

Network Camera

Model No. **WV-SW559/WV-SW558**

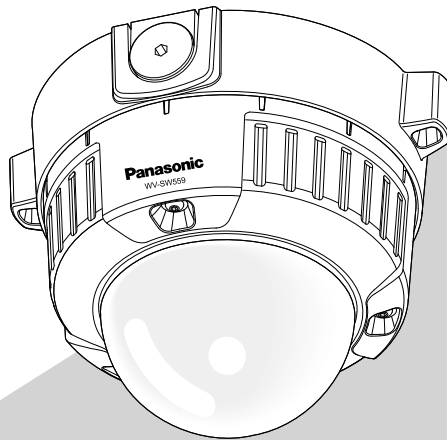

(This illustration represents WV-SW559.)



Before attempting to connect or operate this product,
please read these instructions carefully and save this manual for future use.

The model number is abbreviated in some descriptions in this manual.
This document is the Installation Guide for use in other countries except Japan.

WARNING:

- To prevent injury, this apparatus must be securely attached to the floor/wall/ceiling in accordance with the installation instructions.
- The installation shall be carried out in accordance with all applicable installation rules.
- The connections should comply with local electrical code.

For Canada

CAN ICES-3(A)/NMB-3(A)

For U.S.A

NOTE: This equipment has been tested and found to comply with the limits for a Class A digital device, pursuant to Part 15 of the FCC Rules. These limits are designed to provide reasonable protection against harmful interference when the equipment is operated in a commercial environment. This equipment generates, uses, and can radiate radio frequency energy and, if not installed and used in accordance with the instruction manual, may cause harmful interference to radio communications.

Operation of this equipment in a residential area is likely to cause harmful interference in which case the user will be required to correct the interference at his own expense.

FCC Caution: To assure continued compliance, (example - use only shielded interface cables when connecting to computer or peripheral devices). Any changes or modifications not expressly approved by the party responsible for compliance could void the user's authority to operate this equipment.

For U.S.A

The model number and serial number of this product may be found on the surface of the unit.

You should note the model number and serial number of this unit in the space provided and retain this book as a permanent record of your purchase to aid identification in the event of theft.

Model No. _____
 Serial No. _____

For Europe

We declare under our sole responsibility that the product to which this declaration relates is in conformity with the standard or other normative document following the provisions of Directive 2004/108/EC.

Wir erklären in alleiniger Verantwortung, daß das Produkt, auf das sich diese Erklärung bezieht, mit der folgenden Norm oder normativen Dokument übereinstimmt. Gemäß den Bestimmungen der Richtlinie 2004/108/EC.

Nous déclarons sous notre propre responsabilité que le produit auquel se réfère la présente déclaration est conforme à la norme spécifiée ou à tout autre document normatif conformément aux dispositions de la directive 2004/108/CE.

Nosotros declaramos bajo nuestra única responsabilidad que el producto a que hace referencia esta declaración está conforme con la norma u otro documento normativo siguiendo las estipulaciones de la directiva 2004/108/CE.

Noi dichiariamo sotto nostra esclusiva responsabilità che il prodotto a cui si riferisce la presente dichiarazione risulta conforme al seguente standard o altro documento normativo conforme alle disposizioni della direttiva 2004/108/CE.

Wij verklaren als enige aansprakelijke, dat het product waarop deze verklaring betrekking heeft, voldoet aan de volgende norm of ander normatief document, overeenkomstig de bepalingen van Richtlijn 2004/108/EC.

Vi erklærer os eneansvarlige for, at dette produkt, som denne deklaration omhandler, er i overensstemmelse med standard eller andre normative dokumenter i følge bestemmelserne i direktiv 2004/108/EC.

Vi deklarerar härmed vårt fulla ansvar för att den produkt till vilken denna deklaration hänvisar är i överensstämmelse med standarddokument eller annat normativt dokument som framställs i direktiv 2004/108/EC.

Ilmoitamme yksinomisella vastuullamme, että tuote, jota tämä ilmoitus koskee, noudattaa seuraavaa standardia tai muuta ohjeellista asiakirjaa, jotka noudattavat direktiivin 2004/108/EC sääöksiä.

Vi erklærer oss alene ansvarlige for at produktet som denne erklæringen gjelder for, er i overensstemmelse med følgende norm eller andre normgivende dokumenter som følger bestemmelsene i direktiv 2004/108/EC.

Contents

Important safety instructions.....	4
Limitation of liability.....	5
Disclaimer of warranty.....	5
Preface	6
About notations.....	6
Main functions.....	6
About the user manuals	7
System requirements for a PC	7
Trademarks and registered trademarks.....	8
Copyright.....	9
Network security	9
Precautions	10
Precautions for installation.....	13
Major operating controls	15
Preparations	17
Insert/remove a SD memory card (WV-SW559 Only)*.....	23
Connection	24
Installation	29
Adjustment	34
Configure the network settings	39
Troubleshooting.....	41
Specifications.....	42
Standard accessories.....	46
Optional accessories.....	46

* SDXC/SDHC/SD memory card is described as SD memory card.

Important safety instructions

- 1) Read these instructions.
- 2) Keep these instructions.
- 3) Heed all warnings.
- 4) Follow all instructions.
- 5) Clean only with dry cloth.
- 6) Do not block any ventilation openings. Install in accordance with the manufacturer's instructions.
- 7) Do not install near any heat sources such as radiators, heat registers, stoves, or other apparatus (including amplifiers) that produce heat.
- 8) Do not defeat the safety purpose of the polarized or grounding-type plug. A polarized plug has two blades with one wider than the other. A grounding type plug has two blades and a third grounding prong. The wide blade or the third prong are provided for your safety. If the provided plug does not fit into your outlet, consult an electrician for replacement of the obsolete outlet.
- 9) Protect the power cord from being walked on or pinched particularly at plugs, convenience receptacles, and the point where they exit from the apparatus.
- 10) Only use attachments/accessories specified by the manufacturer.
- 11) Use only with the cart, stand, tripod, bracket, or table specified by the manufacturer, or sold with the apparatus. When a cart is used, use caution when moving the cart/apparatus combination to avoid injury from tip-over.



- 12) Unplug this apparatus during lightning storms or when unused for long periods of time.

Limitation of liability

THIS PUBLICATION IS PROVIDED "AS IS" WITHOUT WARRANTY OF ANY KIND, EITHER EXPRESS OR IMPLIED, INCLUDING BUT NOT LIMITED TO, THE IMPLIED WARRANTIES OF MERCHANTABILITY, FITNESS FOR ANY PARTICULAR PURPOSE, OR NON-INFRINGEMENT OF THE THIRD PARTY'S RIGHT.

THIS PUBLICATION COULD INCLUDE TECHNICAL INACCURACIES OR TYPOGRAPHICAL ERRORS. CHANGES ARE ADDED TO THE INFORMATION HEREIN, AT ANY TIME, FOR THE IMPROVEMENTS OF THIS PUBLICATION AND/OR THE CORRESPONDING PRODUCT (S).

Disclaimer of warranty

IN NO EVENT SHALL Panasonic System Networks Co., Ltd. BE LIABLE TO ANY PARTY OR ANY PERSON, EXCEPT FOR REPLACEMENT OR REASONABLE MAINTENANCE OF THE PRODUCT, FOR THE CASES, INCLUDING BUT NOT LIMITED TO BELOW:

- (1) ANY DAMAGE AND LOSS, INCLUDING WITHOUT LIMITATION, DIRECT OR INDIRECT, SPECIAL, CONSEQUENTIAL OR EXEMPLARY, ARISING OUT OF OR RELATING TO THE PRODUCT;
- (2) PERSONAL INJURY OR ANY DAMAGE CAUSED BY INAPPROPRIATE USE OR NEGLIGENT OPERATION OF THE USER;
- (3) ALL MALFUNCTIONS OR TROUBLES FROM UNAUTHORIZED DISASSEMBLE, REPAIR OR MODIFICATION OF THE PRODUCT BY THE USER, REGARDLESS OF THE CAUSE OF THE MALFUNCTION OR TROUBLE;
- (4) INCONVENIENCE OR ANY LOSS ARISING WHEN IMAGES ARE NOT DISPLAYED, DUE TO ANY REASON OR CAUSE INCLUDING ANY FAILURE OR PROBLEM OF THE PRODUCT;
- (5) ANY PROBLEM, CONSEQUENTIAL INCONVENIENCE, OR LOSS OR DAMAGE, ARISING OUT OF THE SYSTEM COMBINED BY THE DEVICES OF THIRD PARTY;
- (6) ANY CLAIM OR ACTION FOR DAMAGES, BROUGHT BY ANY PERSON OR ORGANIZATION BEING A PHOTOGENIC SUBJECT, DUE TO VIOLATION OF PRIVACY WITH THE RESULT OF THAT SURVEILLANCE-CAMERA'S PICTURE, INCLUDING SAVED DATA, FOR SOME REASON, BECOMES PUBLIC OR IS USED FOR ANY PURPOSE;
- (7) LOSS OF REGISTERED DATA CAUSED BY ANY FAILURE.

Preface

The network camera WV-SW559/WV-SW558 is designed to operate using a PC on a network (10BASE-T/100BASE-TX), and can be installed under eaves (sheltered outdoor). By connecting to a network (LAN) or the Internet, images and audio from the camera can be monitored on a PC via a network.

Note:

- It is necessary to configure the network settings of the PC and its network environment to monitor images from the camera on the PC. It is also necessary to install a web browser on the PC.
-

About notations

The following notations are used when describing the functions limited for specified models. The functions without the notations are supported by all models.

SW559: The functions with this notation are available when using the model WV-SW559.

SW558: The functions with this notation are available when using the model WV-SW558.

Main functions

H.264 and JPEG triple encoding

H.264 dual stream output and JPEG output can be simultaneously provided.

* H.264 stream1: 1920x1080/ max. 30 fps

H.264 stream2: 640x360/ max. 30 fps

Cropping function (the function of cutting out the image capture area)

At the same time as providing the whole image, it is possible to provide the part cut out from whole image. Up to 4 image capture areas can be specified, and it is also possible to control the sequence.

* It is possible to control its sequence and transmit the image cut out only when H.264 stream2 is provided.

VIQS function (Variable Image Quality on Specified area)

It is possible to provide specified areas with high quality image without changing the overall size of the data. Up to 2 areas can be specified.

SDXC/SDHC/SD memory card slot equipped **SW559**

It is possible to save H.264 videos and JPEG images on the SDXC/SDHC/SD memory card manually at an alarm occurrence, during the period of the schedule, or on a web browser. It is also possible to save JPEG images at a network failure occurrence. (Download is possible.)

(Recommended SDXC/SDHC/SD memory card ⓘ page 45)

Super Dynamic

(ⓘ Operating Instructions (included in the CD-ROM))

Super Dynamic compensates brightness on a pixel-to-pixel basis so that it produces clearer images even if objects have various illumination intensities.

Auto focus (AF) function

It is possible to adjust the focus automatically by moving the focus ring of the lens with the operation button of this camera or the setup menu.

About the user manuals

There are 2 sets of operating instructions for the WV-SW559, WV-SW558 as follows.

- Installation Guide: Explains how to install and connect devices.
- Operating Instructions (included in the CD-ROM): Explains how to perform the settings and how to operate this camera.

Adobe® Reader® is required to read these operating instructions on the provided CD-ROM.

When the Adobe Reader is not installed on the PC, download the latest Adobe Reader from the Adobe web site and install it.

"SW559, SW558" shown in the instructions and illustrations used in these operating instructions indicates the WV-SW559, WV-SW558.

English screens are used in these operating instructions.

System requirements for a PC

CPU:	Intel® Core™ 2 Duo 2.4 GHz or faster recommended
Memory:	512 MB or more (A minimum of 1 GB memory is required when using Microsoft® Windows® 7 or Microsoft® Windows Vista®.)
Network interface:	10BASE-T/100BASE-TX 1 port
Audio interface:	Sound card (when using the audio function)
Monitor:	Image capture size: 1024 x 768 pixels or more Color: 24-bit True color or better
OS:	Microsoft® Windows® 7 Microsoft® Windows Vista® Microsoft® Windows® XP SP3
Web browser:	Windows® Internet Explorer® 9.0 (32-bit) Windows® Internet Explorer® 8.0 (32-bit) Windows® Internet Explorer® 7.0 (32-bit) Microsoft® Internet Explorer® 6.0 SP3
Others:	CD-ROM drive (It is necessary to read the operating instructions and use the software on the provided CD-ROM.) DirectX® 9.0c or later Adobe® Reader® (It is necessary to view the PDF file on the provided CD-ROM.)

IMPORTANT:

- When using a PC that does not meet the above requirements, displaying of images may become slower or the web browser may become inoperable.
 - Audio may not be heard if a sound card is not installed on a PC. Audio may be interrupted depending on the network environment.
 - Microsoft Windows 7 Starter, Microsoft Windows Vista Starter and Microsoft Windows XP Professional 64-bit Edition are not supported.
 - When using IPv6 for communication, use Microsoft Windows 7 or Microsoft Windows Vista.
-

Note:

- For further information about PC system requirements and precautions for when using Microsoft Windows 7, Microsoft Windows Vista, or Windows Internet Explorer, click "Manual" - "Open" from the supplied CD-ROM and refer to "Notes on Windows® / Internet Explorer® versions".
 - If using Microsoft Windows XP, screen tearing* may occur when the shooting scene drastically changes (for example, while shooting fast-moving subjects) due to the GDI restrictions of the OS.
* A phenomenon in which portions of the screen are displayed out of alignment
 - For information on the operation verification of the supported operating systems and web browsers, refer to our website at <http://security.panasonic.com/pss/security/support/index.html>.
-

Trademarks and registered trademarks

- Adobe, Acrobat Reader, and Reader are either registered trademarks or trademarks of Adobe Systems Incorporated in the United States and/or other countries.
- Microsoft, Windows, Windows Vista, Internet Explorer, ActiveX, and DirectX are either registered trademarks or trademarks of Microsoft Corporation in the United States and/or other countries.
- Microsoft product screen shot(s) reprinted with permission from Microsoft Corporation.
- Intel and Intel Core are trademarks or registered trademarks of Intel Corporation or its subsidiaries in the United States and other countries.
- SDXC Logo is a trademark of SD-3C, LLC.
- iPad, iPhone, and iPod touch are trademarks of Apple Inc., registered in the U.S. and other countries.
- Android is a trademark of Google Inc. Use of this trademark is subject to Google Permissions.
- All other trademarks identified herein are the property of their respective owners.

Copyright

Distributing, copying, disassembling, reverse compiling and reverse engineering of the software provided with this product are all expressly prohibited. In addition, exporting any software provided with this product violating export laws is prohibited.

Network security

As you will use this unit connected to a network, your attention is called to the following security risks.

- ① Leakage or theft of information through this unit
- ② Use of this unit for illegal operations by persons with malicious intent
- ③ Interference with or stoppage of this unit by persons with malicious intent

It is your responsibility to take precautions such as those described below to protect yourself against the above network security risks.

- Use this unit in a network secured by a firewall, etc.
- If this unit is connected to a network that includes PCs, make sure that the system is not infected by computer viruses or other malicious entities (using a regularly updated anti-virus program, anti-spyware program, etc.).
- Protect your network against unauthorized access by restricting users to those who log in with an authorized user name and password.
- Apply measures such as user authentication to protect your network against leakage or theft of information, including image data, authentication information (user names and passwords), alarm mail information, FTP server information and DDNS server information.
- After the unit is accessed by the administrator, make sure to close the browser.
- Change the administrator password periodically.
- Do not install the camera in locations where the camera or the cables can be destroyed or damaged by persons with malicious intent.

Precautions

Refer installation work to the dealer.

Installation work requires technique and experiences. Failure to observe this may cause fire, electric shock, injury, or damage to this product.

Be sure to consult the dealer.

Stop the operation immediately when something is wrong with this product.

When smoke goes up from the product, the smell of smoke comes from the product, or the exterior of the product has deteriorated, continued use will cause a fire or fall of the product resulting in injury, accidents, or damage to the product.

Turn the power off immediately and contact qualified service personnel for service.

Do not attempt to disassemble or modify this product.

Failure to observe this may cause fire or electric shock.

Consult the dealer for the repair or inspections.

Do not insert any foreign objects.

This could permanently damage this product.

Turn the power off immediately and contact qualified service personnel for service.

Select an installation area that can support the total weight.

Selecting an inappropriate installation surface may cause this product to fall down or topple over, resulting in injury.

Installation work shall be started after sufficient reinforcement.

Periodic inspections shall be conducted.

Rust on the metal parts or screws may cause a fall of the product resulting in injury or accidents.

Consult the dealer for the inspections.

Do not use this product in an inflammable atmosphere.

Failure to observe this may cause an explosion resulting in injury.

Avoid installing this product in the locations where salt damage occurs or corrosive gas is produced.

Otherwise, the mounting portions will deteriorate and accidents such as a fall of the product may occur.

The exclusively designed mount bracket shall be used.

Failure to observe this may cause a drop resulting in injury or accidents.

Use the exclusively designed mount bracket for installation.

The screws and bolts must be tightened to the specified torque.

Failure to observe this may cause a drop resulting in injury or accidents.

Do not install this product in locations subject to vibration.

Loosening of mounting screws or bolts may cause a fall of the product resulting in injury.

Install this product in a location high enough to avoid people and objects from bumping the product.

Failure to observe this may cause a drop resulting in injury or accidents.

Do not strike or give a strong shock to this product.

Failure to observe this may cause fire or injury.

Turn the power off when do wiring of this product.

Failure to observe this may cause electric shock. In addition, short circuit or wrong wiring may cause fire.

Do not rub the edges of metal parts with your hand.

Failure to observe this may cause injury.

Do not touch this product, the power cord or the connected cables during thunder. (even in the process of work)

Failure to observe this may cause electric shock.

Keep SDXC/SDHC/SD memory cards (option) away from infants and children.

Otherwise, they may swallow the cards by mistake.

In this case, consult a doctor immediately.

Do not damage the power cable.

Do not damage, fabricate, twist, stretch, bundle, or forcibly bend the power cable. Do not place heavy objects.

Keep away from heat sources.

Use of the damaged power cable may cause electric shock, short circuit, or fire.

Consult the dealer for repair.

Turn the power off when cleaning this product.

Failure to observe this may cause injury.

[Precautions for use]

This product has no power switch.

When turning off the power, disconnect the power supply from the 12V DC power supply or the PoE device. (When using both the 12V DC power supply and the PoE device for power supply, disconnect both the connections.)

To keep on using with stable performance

Do not use this product in hot and humid conditions for a long time. Failure to observe this causes component degradation resulting in life shortening of this product.

Do not expose the product to direct heat sources such as a heater.

Do not touch the dome cover with your bare hands.

A dirty dome cover causes deterioration of picture quality.

Handle this product with care.

Do not drop this product, nor apply shock or vibration to the product. Failure to observe this may cause trouble. If a strong shock or vibration is applied to the enclosure, it may cause damage or allow water to enter this product.

About the PC monitor

Displaying the same image on a monitor for a long time may damage the monitor. It is recommended to use a screen-saver.

When an error is detected, this product will restart automatically.

This product will be inoperable for around 2 minutes after the restart just as when the power is turned on.

Product disposal/transfer

Data saved on this product or a storage device used with this product may lead to personal information leakage. When it is necessary to dispose or give this product to someone, even when for repair, make sure that there is no data on this product.

Cleaning this product body

Be sure to turn off the power before cleaning. Failure to observe this may cause injury. Do not use strong abrasive detergent when cleaning this product. Otherwise, it may cause discoloration.

When using a chemical cloth for cleaning, read the caution provided with the chemical cloth product.

Cleaning the lens

Use a lens cleaning paper (used to clean camera lenses or lenses of spectacles). When using solvent, use an alcohol solvent and do not use a thinner or a glass cleaner.

Transmission interval

Image transmission interval may become slow depending on the network environment, PC performance, shooting subject, access number, etc.

What to do if "WARMING UP-PLEASE WAIT" appears on the display.

This message indicates that the temperature inside the camera has become extremely low.

In such a case, wait until the heater unit of the camera raises the internal temperature (for around 2 hours or more in low temperatures below -10 °C {14 °F}), and turn on the power again.

About SD memory card

- Before removing the SD memory card, make sure to select “Not use” for “SD memory card” on the [SD memory card] tab of “Basic” page on the setup menu first. (☞ Operating Instructions (included in the CD-ROM)) Refer to page 23 for descriptions of how to insert/remove an SD memory card.
- When using a SD memory card, format it using this product. Recorded data on the SD memory card will be deleted when formatted. If an unformatted SD memory card or a SD memory card formatted with other devices is used, this product may not work properly or performance deterioration may be caused. Refer to the Operating Instructions (included in the CD-ROM) for how to format a SD memory card.
- When some SD memory cards are used with this product, the product may not work properly or performance deterioration may be caused.

Code label

The code labels (accessory) are required at inquiry for trouble. Use caution not to lose these labels. It is recommended to paste one of the labels onto the CD-ROM case.

Discoloration on the color filter of the MOS image sensor

- When continuously shooting a bright light source such as a spotlight, the color filter of the MOS image sensor may have deteriorated and it may cause discoloration. Even when changing the fixed shooting direction after continuously shooting a spotlight for a certain period, the discoloration may remain.
- When shooting fast-moving subjects or performing panning/tilting operations, objects crossing the shooting area may look to be bending askew.

AVC Patent Portfolio License

THIS PRODUCT IS LICENSED UNDER THE AVC PATENT PORTFOLIO LICENSE FOR THE PERSONAL USE OF A CONSUMER OR OTHER USES IN WHICH IT DOES NOT RECEIVE REMUNERATION TO (i) ENCODE VIDEO IN COMPLIANCE WITH THE AVC STANDARD (“AVC VIDEO”) AND/OR (ii) DECODE AVC VIDEO THAT WAS ENCODED BY A CONSUMER ENGAGED IN A PERSONAL ACTIVITY AND/OR WAS OBTAINED FROM A VIDEO PROVIDER LICENSED TO PROVIDE AVC VIDEO. NO LICENSE IS GRANTED OR SHALL BE IMPLIED FOR ANY OTHER USE. ADDITIONAL INFORMATION MAY BE OBTAINED FROM MPEG LA, L.L.C.
SEE [HTTP://WWW.MPEGLA.COM](http://www.mpegla.com)

About the dehumidifying device

- This product has dehumidifying device to keep the inside at low moisture level, preventing condensation and quickly dissipating dew if produced.
- Dew may be produced depending on the conditions of temperature, humidity, winds, and rain, and it may take time to dehumidify.
- Never seal the surfaces of the dehumidifying device.

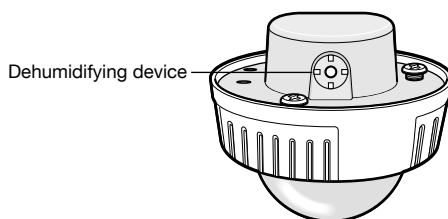

Precautions for installation

Panasonic assumes no responsibility for injuries or property damage resulting from failures arising out of improper installation or operation inconsistent with this documentation.

This product is designed to be installed under eaves.

Install the product under eaves to avoid direct sunlight.

Installing place

Contact your dealer for assistance if you are unsure of an appropriate place in your particular environment.

- Make sure that the installation area is strong enough to hold this product, such as a concrete ceiling.
- Install the camera in the foundation area of the architecture or where sufficient strength is assured.
- If a ceiling board such as plaster board is too weak to support the total weight, the area shall be sufficiently reinforced.

Do not place this product in the following places:

- Locations where a chemical agent is used such as a swimming pool
- Locations subject to moisture or oil smoke such as a kitchen
- Locations that have a specific environment that is subject to an inflammable atmosphere or solvents
- Locations where a radiation, an X-ray, a strong radio wave or a strong magnetic field is generated
- Locations where corrosive gas is produced, locations where it may be damaged by briny air such as seashores
- Locations where the temperature is not within the specified range (page 42).
- Locations subject to vibrations (This product is not designed for on-vehicle use.)

Do not install this product in a humid or dust-laden environment.

Otherwise, lifetime of the internal parts may be shortened.

Be sure to remove this product if it is not in use.

Design and engineer the power supply system to turn on/off the power of this product.

The product has no power switch. When installing the product, use a power supply device equipped with the ON-OFF switch for servicing.

About the network connection

When connecting to a network using the network cable of this product, observe the following.

- When wiring for the network, design and engineer not to be affected by thunder.
- It is impossible to install this product in combination with a pan/tilt head.

Screw tightening

- The screws and bolts must be tightened with an appropriate tightening torque according to the material and strength of the installation area.
- Do not use an impact driver. Use of an impact driver may damage the screws or cause tightening excessively.
- Tighten screws at a right angle to the surface. After tightening screws, perform visual check to ensure tightening is so sufficient that there is no backlash.

Procure fixing screws separately.

The screws that secure this product are not supplied. Prepare them according to the material and strength of the area where the product is to be installed.

Do not remove or loosen the screws on the rear of this product.

If the screws (7 pcs.) are loosened, water exposure may cause damage or malfunction of the product, or dropping may result in injury.

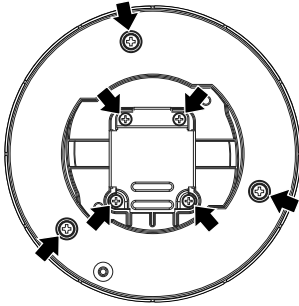

Radio disturbance

When this product is used near TV/radio antenna, strong electric field or magnetic field (near a motor, a transformer or a power line), images may be distorted and noise sound may be produced.

Take notice of humidity.

Install this product when the humidity is low. If this product is installed during rainfall or at a high humidity, the inside may be exposed to moisture and the dome cover may become foggy.

Heater unit

This product is equipped with an internal heater unit for use in cold climates. The heater unit turns on automatically when the temperature inside the product drops below 0 °C {32 °F}. However, in an extremely low-temperature environment below -30 °C {-22 °F}, snow and frost may not be defrosted from the dome cover. When using the product in cold climates, take notice of the ambient and internal temperatures of the product.

When this product is installed and operated in low temperatures below -10 °C {14 °F}, normal images may not be obtained immediately after startup. In such a case, wait around 2 hours or more, and turn on the power again.

PoE (Power over Ethernet)

Use a PoE hub/device that is compliant with IEEE802.3af standard.

Router

When connecting this product to the Internet, use a broadband router with the port forwarding function (NAT, IP masquerade).

Refer to the Operating Instructions (included in the CD-ROM) for further information about the port forwarding function.

Time & date setting

It is necessary to set the time & date before putting this product into operation. Refer to the Operating Instructions on the provided CD-ROM for descriptions of how to perform the settings.

Major operating controls

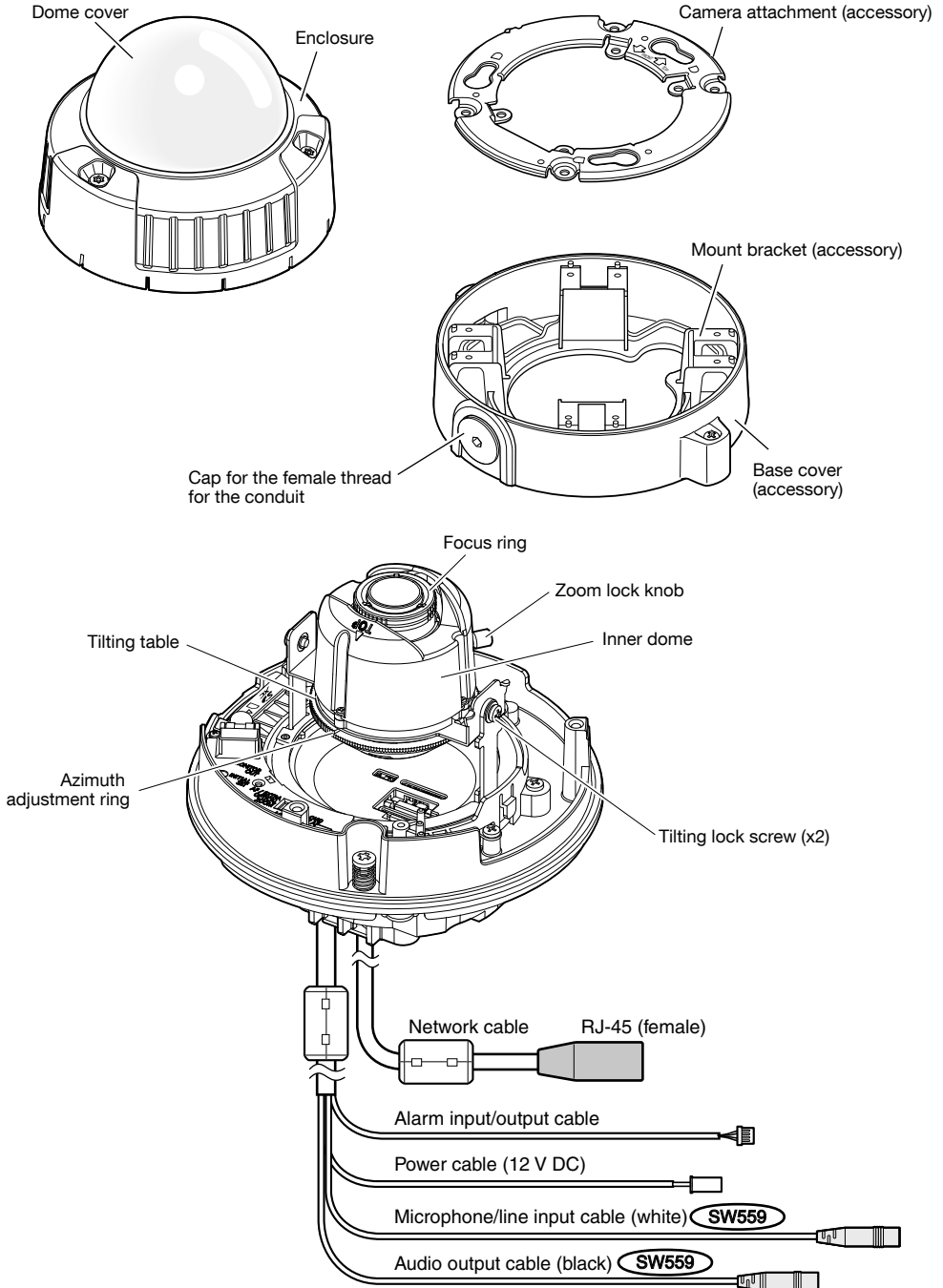

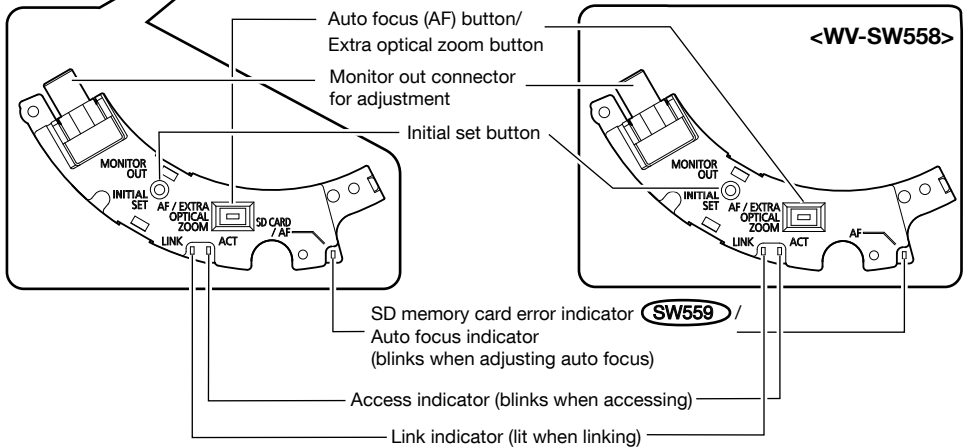
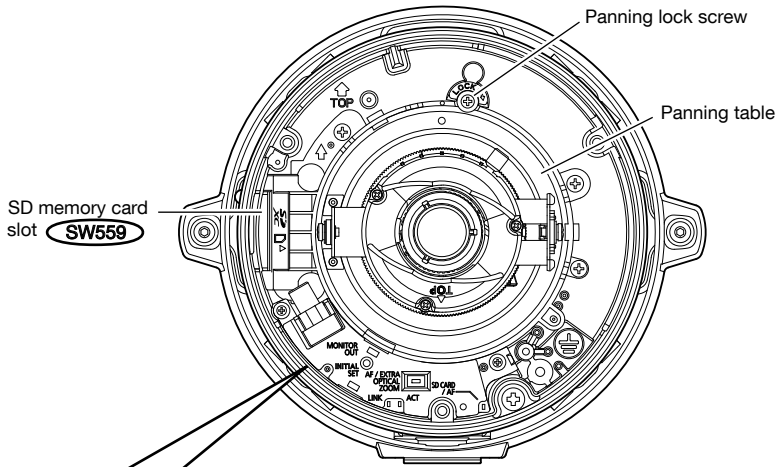

About the [INITIAL SET] button

After turning off the power of the camera, turn on the power of the camera while holding down this button, and wait for around 5 seconds or more without releasing the button. Wait around 2 minutes after releasing the button. The camera will start up and the settings including the network settings will be initialized. Do not turn off the power of the camera during the process of initialization. Before initializing the settings, it is recommended to copy down the settings in advance.

Preparations

When installing the camera on a wall or a ceiling, there are two methods as specified below.

- Using a two-gang junction box
- Use the supplied mount bracket

IMPORTANT:

- Procure 4 screws (M4) to secure the camera attachment (accessory) or the mount bracket (accessory) to a wall or a ceiling according to the material of the installation area. Do not use wood screws and nails.

For mounting a camera on a concrete ceiling, use an anchor bolt (for M4) or an AY plug bolt (M4) for securing.

(Recommended tightening torque M4: 1.6 N·m {1.18 lbf·ft})

- Mount the camera attachment (accessory) in consideration of the camera angle in accordance with the instructions (pages 18 and 19).
 - Required pull-out capacity of a single screw/bolt is 196 N {44.06 lbf} or more.
 - If a ceiling board such as plaster board is too weak to support the total weight, the area shall be sufficiently reinforced.
-

The mounting conditions of the camera are described as follows:

Installation place	Appropriate mount bracket	Recommended screw	Number of screw	Minimum pull-out strength (per 1 pc.)
Ceiling/wall	Two-gang junction box	M4	4 pcs.	196 N {44.06 lbf}
Ceiling/wall*	Mount bracket (accessory) (Approx. 350 g {0.77 lbs.})	M4	4 pcs.	196 N {44.06 lbf}

* The conditions for securing the mount bracket to a wall or a ceiling are described here.

Using a two-gang junction box

- Secure the camera attachment (accessory) to the two-gang junction box built in a wall or ceiling using the fixing screws (accessory).

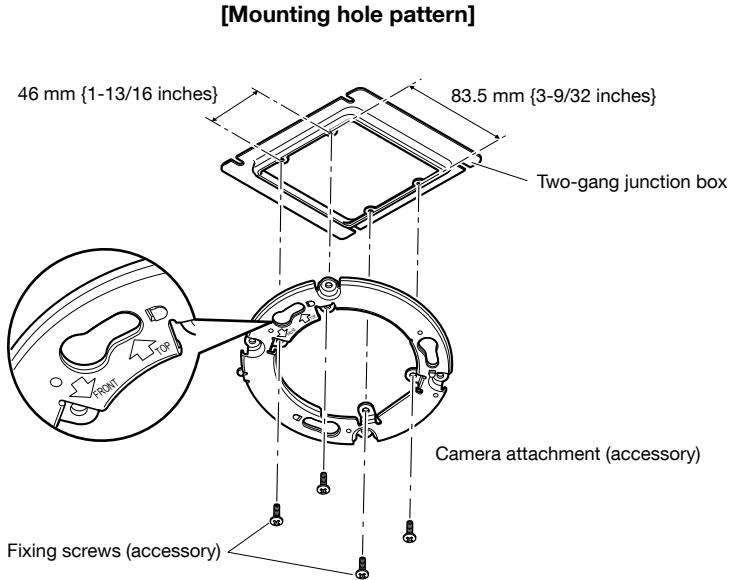

Note:

- For wall mounting:
The camera attachment (accessory) shall be mounted with "↑TOP" facing upward.
 - For ceiling mounting:
The camera attachment (accessory) shall be mounted with "↓FRONT" facing in the direction of the camera front (the side where the Panasonic logo is).
-

Using the mount bracket (accessory)

Note:

- When the camera is mounted on the wall or ceiling with a hole for cable running, or the camera is mounted using open wiring, the mount bracket is used.
-

IMPORTANT:

- If open wiring is conducted, be sure to use conduits and run the cables inside the tubes to protect the cables from direct sunlight.
- Installation work shall be such that there is no exposure to water into the architecture through the conduits having been joined.

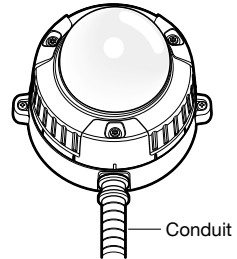

-
- 1** Loosen two fixing screws on both ends of the base cover (accessory) by using the bit for tamperproof screw (accessory), and remove the base cover (accessory). When using a conduit, use a hexagon wrench (ISO 2936, width across flats S=5 mm {13/64 inches}) or other tool and also remove the cap for the female thread for the conduit.
-

Note:

- The female thread for conduit is compliant with ANSI NPSM (parallel pipe threads) 3/4 inch or G3/4 of ISO 228-1.
-

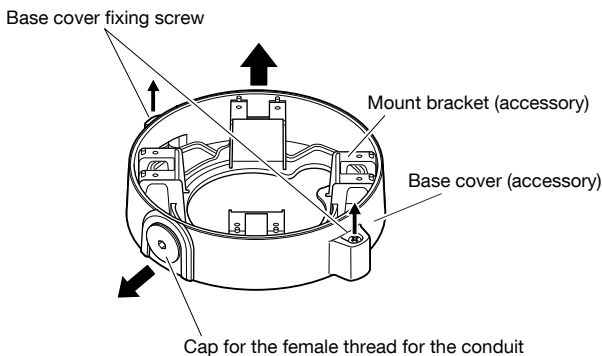

- 2** Determine the direction of the mount bracket according to the installation environment (how the cables are wired, etc.) before mounting it to a wall or ceiling.
The direction of the camera in relation to the mount bracket is the 4 directions as shown in illustration.

Note:

- The camera's direction is determined by the direction of the camera attachment (accessory) mounted to the mount bracket **3**.
- For wall mounting:
The camera's upwards direction (the side opposite to where the Panasonic log is) is fixed. Select which direction to make the upward direction for the mount bracket.
- For ceiling mounting:
Select which direction to face the front (the side where the Panasonic logo is) of the camera.

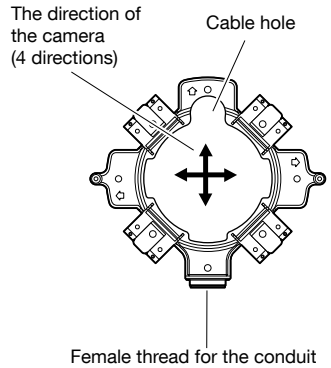

<Using the cable access hole>

Open the camera access hole on the wall or ceiling as shown in the illustration. Align the cable hole of the mount bracket to the hole, and mount the bracket to hole (A) or hole (B) on the wall or ceiling.

[For use of the hole (A)]

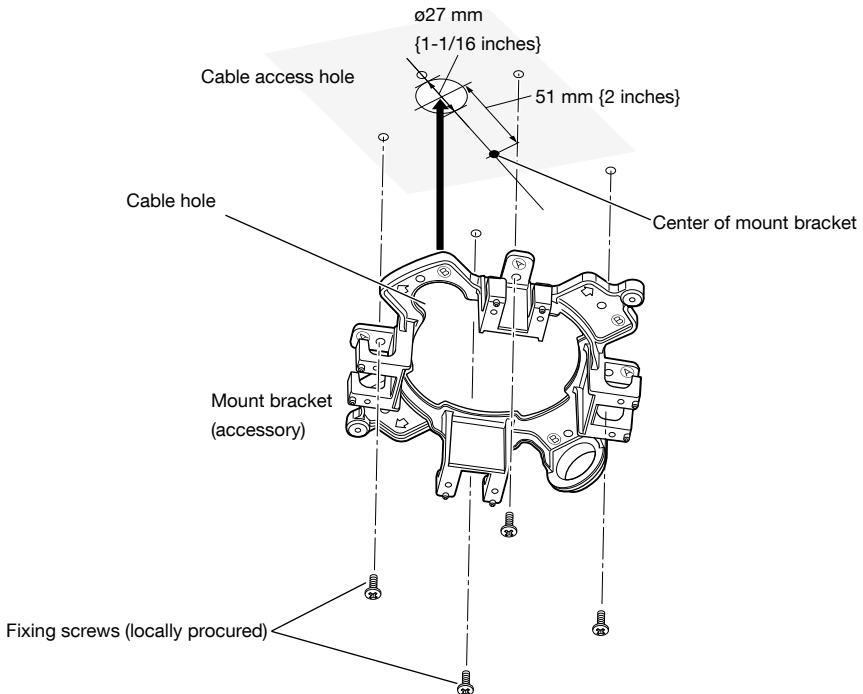

<Using a conduit>

Align the direction of the conduit to the direction of female thread for the conduit on the mount bracket, and mount the mount bracket to hole (A) or hole (B) on the wall or ceiling.

[For use of the hole (A)]

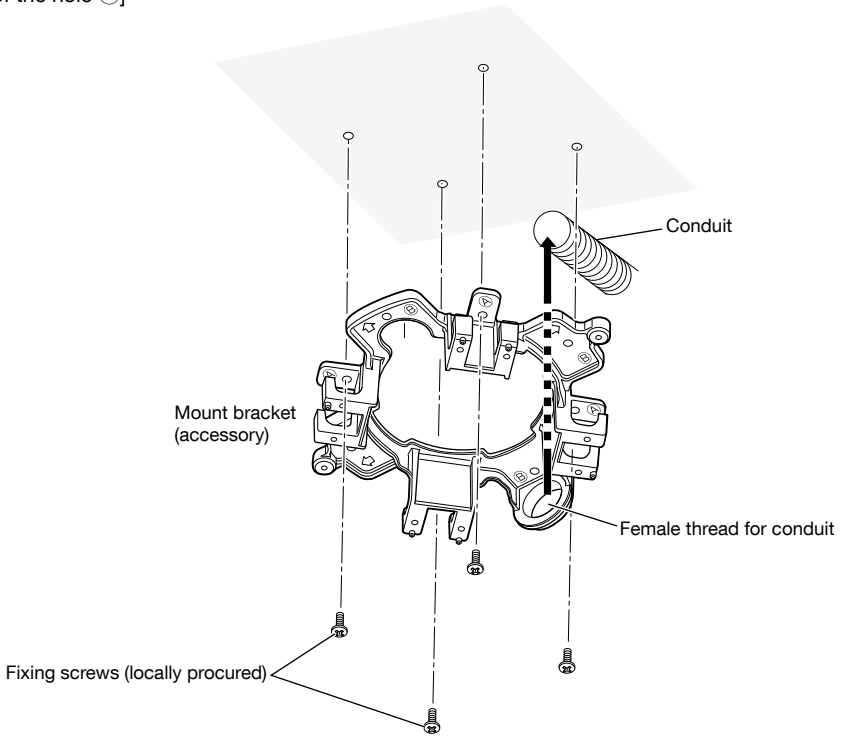

Note:

- Only the same type of holes, (A) or (B), shall be used for mounting.

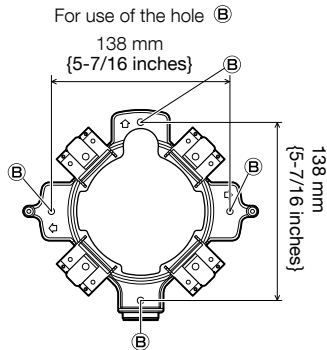
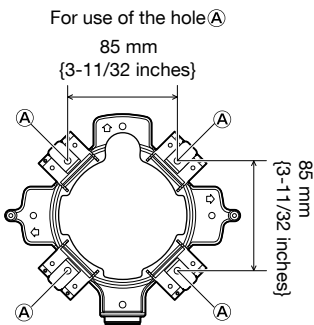

- 3** In the direction determined in **2**, fix the camera attachment (accessory) on the mount bracket using the fixing screws. Recommended tightening torque: 0.78 N·m {0.58 lbf·ft}

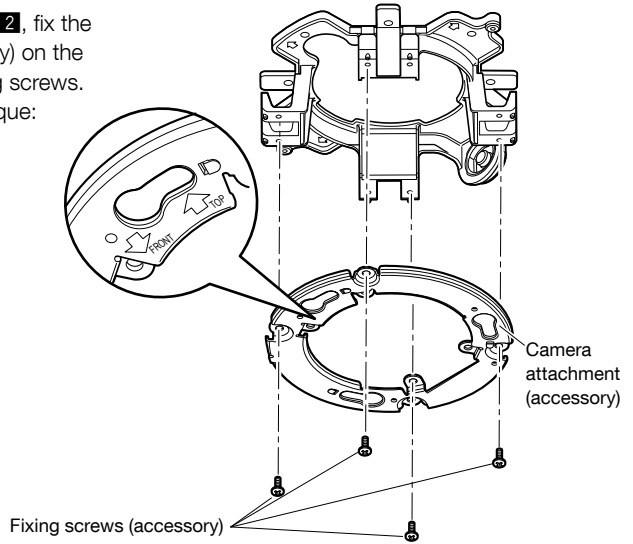

Note:

- For wall mounting:
The camera attachment (accessory) shall be mounted with "↑TOP" facing upward.
 - For ceiling mounting:
The camera attachment (accessory) shall be mounted with aligning the front side (the side where the Panasonic logo is) of the camera with the position of the arrow in "↓FRONT".
-

IMPORTANT:

- For installations on the wall, to prevent water from accumulating on the surface of the dehumidifying device (☞ page 12), do not connect it at the upper side.
If water remains inside, the dehumidifying device cannot function properly.
-

- 4** Pass the cables through the hole for cable running from the wall or ceiling, and then pass the cables between the camera attachment (accessory) and mount bracket to the outside.

Insert/remove a SD memory card (WV-SW559 Only)

IMPORTANT:

- When inserting a SD memory card, make sure the direction.
- Before removing the SD memory card, make sure to select “Not use” for “SD memory card” on the [SD memory card] tab of the “Basic” page on the setup menu first. (☞ Operating Instructions (included in the CD-ROM))

- 1** Detach the enclosure. (☞ Page 32)
- 2** Insert a SD memory card fully into the SD memory card slot until a click is heard.
- 3** Attach the enclosure to the camera.
(☞ Page 38)
- 4** When removing the SD memory card from the SD memory card slot, detach the enclosure (☞ page 32), and push the card until a click is heard. After the SD memory card is removed, attach the enclosure to the camera again.
(☞ Page 38)

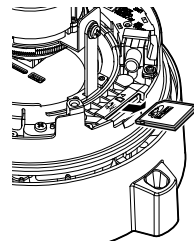
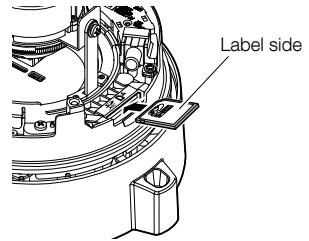

Connection

Caution:

- ONLY CONNECT 12 V DC CLASS 2 POWER SUPPLY (UL 1310/CSA 223) or LIMITED POWER SOURCE (IEC/EN/UL/CSA 60950-1).

Before starting the connection, turn off the power of this camera and the devices to be connected. Check and prepare the required devices and cables for connection.

Note:

- When using the mount bracket (accessory), it is possible to connect the cables after mounting the camera onto the mount bracket.
- Refer to page 19 when connecting the conduit.

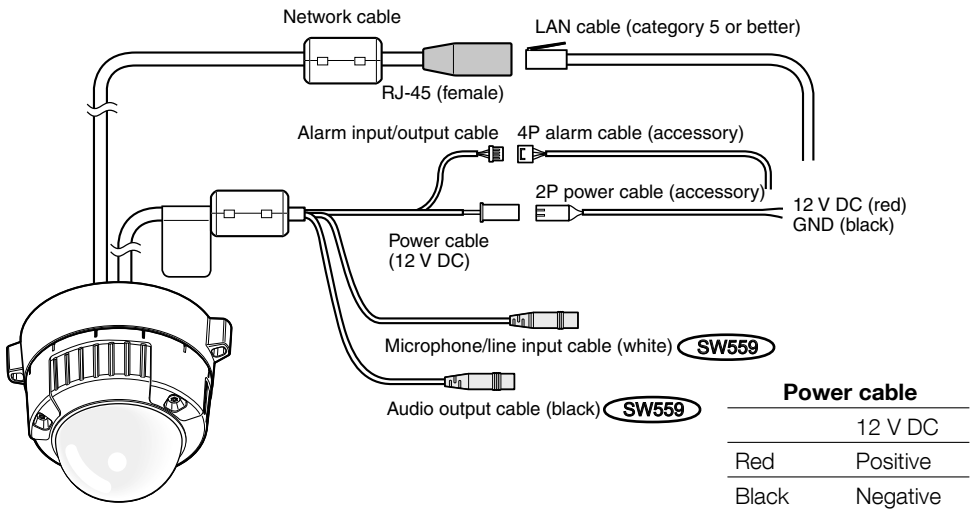

- 1 Connect the microphone/line input cable and the microphone (for use of the audio reception function). **SW559**

Input impedance: $2\text{ k}\Omega \pm 10\%$
 Recommended cable length: Less than 1 m {3.28'} (for microphone input)
 Less than 10 m {32.8'} (for line input)
 Recommended microphone: Plug-in power type microphone (option)
 Connect a monaural mini plug ($\varnothing 3.5\text{ mm}$).
 Supply voltage: $2.5\text{ V} \pm 0.5\text{ V}$
 Recommended sensitivity of microphone: $-48\text{ dB} \pm 3\text{ dB}$ ($0\text{ dB} = 1\text{ V/Pa}$, 1 kHz)

IMPORTANT:

- Connect/disconnect the external speaker cables or audio/video cables after turning off the power of the camera and the amplifier. Otherwise, loud noise may come out from the speaker.

- 2 Connect an external amplifier-embedded speaker to the audio output cable (for use of the audio transmission function). **SW559**
 Connect a stereo mini plug (ø3.5 mm) (Audio output is monaural.).
- Recommended cable length: Less than 10 m {32.8 ft}

- 3 Connect the alarm input/output cable.

<Ratings>

Terminal name	Ratings
ALARM OUT, AUX OUT	Open collector output (maximum applied voltage: 20 V DC)
Open	4 V DC - 5 V DC by internal pull-up
Close	Output voltage 1 V DC or less (50 mA or less)
ALARM IN, DAY/NIGHT IN	Non-voltage make contact input (4 V DC - 5 V DC, internally pulled up)
Off	Open or 4 V DC - 5 V DC
On	Make contact with GND (required drive current: 1 mA or more)

Note:

- Check if rating of an external device such as a sensor is applicable to the rating of this product by referring to the provided operating instructions.

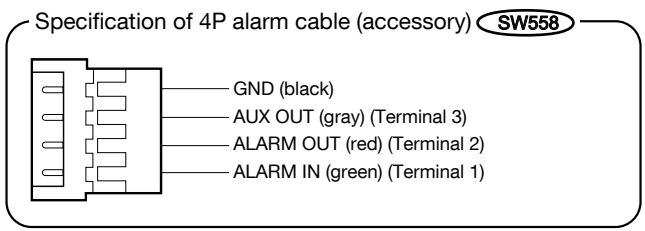
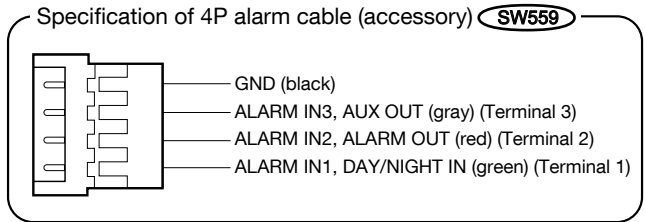

IMPORTANT:

- Input and output of the EXT I/O terminal 2 and 3 can be switched by configuring the setting. "Off" is selected by default. It is possible to determine whether or not to receive input from EXT I/O terminal 2 and 3 (ALARM IN2, 3) by selecting "Off", "Alarm input", "Alarm output" or "AUX output" for "Terminal 2" or "Terminal 3" on the [Alarm] tab on the "Alarm" page. Refer to the Operating Instructions (included in the CD-ROM) for further information.
 - When using the EXT I/O terminals as the output terminals, ensure they do not cause signal collision with external signals.
 - In order for the EXT I/O terminal to detect alarm inputs when the terminal status is changed from Open to Close (On) or from Close to Open (Off), about 100 ms or more is needed. Because alarms cannot be detected for about 5 seconds after a detection is made, alarm inputs received within about 5 seconds after an alarm is detected are not detected.
-

4 Connect a LAN cable (category 5 or better, straight, STP*) to the network connector.
* For Europe

5 Connect the power cable.

- **When using 12 V DC power supply*1**

Connect the output cable of the AC adaptor to the 2P power cable.

- **When using PoE (IEEE802.3af compliant)**

Connect a LAN cable (category 5 or better, straight, STP*2) between a PoE device (such as a hub) and the network connector of the camera.

*1 ONLY CONNECT 12 V DC CLASS 2 POWER SUPPLY (UL 1310/CSA 223) or LIMITED POWER SOURCE (IEC/EN/UL/CSA 60950-1).

*2 For Europe

IMPORTANT:

- Use all 4 pairs (8 pins) of the LAN cable.
 - The maximum cable length is 100 m {328 feet}.
 - Make sure that the PoE device in use is compliant with IEEE802.3af standard.
 - When connecting both the 12 V DC power supply and the PoE device for power supply, 12 V DC will be used for power supply. Depending on the PoE device used, the power supply lamp may not light and the network connections may not be possible. In this case, disable the PoE device setting, and refer to the operating instructions of the PoE device in use.
 - When the LAN cable is disconnected once, reconnect the cable after about 2 seconds. When the cable is quickly reconnected, the power may not be supplied from the PoE device.
-

Waterproof treatment for the cable joint sections

Adequate waterproof treatment is required for the cables when installing the camera with cables exposed or installing it under the eaves. The camera body is waterproof, but the cable ends are not waterproof.

Be sure to use the supplied waterproof tape at the points where the cables are connected to apply waterproof treatment in the following procedure. Failure to observe this or use of a tape other than the provided waterproof tape (such as a vinyl tape) may cause water leakage resulting in malfunction.

LAN cable

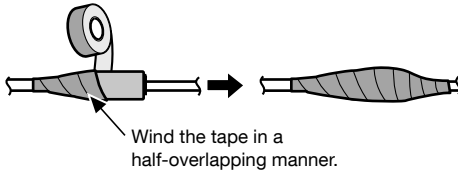

Alarm input/output cable, power cable, microphone/line input cable*, audio output cable*

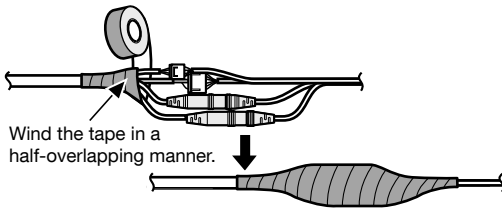

* **SW559**

IMPORTANT:

- Waterproof treatment is also to be applied to the 2P power cable (accessory), the 4P alarm cable (accessory) and other connection cables if they are subject to rain.

Note:

How to wind the supplied waterproof tape

- Stretch the tape by approx. twice (see the illustration) and wind it around the cable. Insufficient tape stretch causes insufficient waterproofing.
- Make sure to wind the tape so that it does not press down on the hook of the network cable.
- To install this product outdoors, be sure to waterproof the cables. Waterproof grade (IEC IP66 or equivalent) is applied to this product only when it is installed correctly as described in these operating instructions and appropriate waterproof treatment is applied. The mount brackets are not waterproofed.

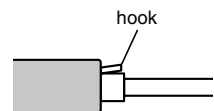
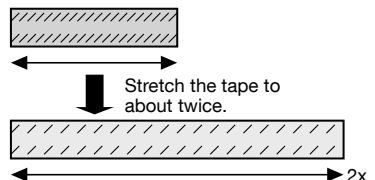

Connection example when connecting to a network using a PoE hub

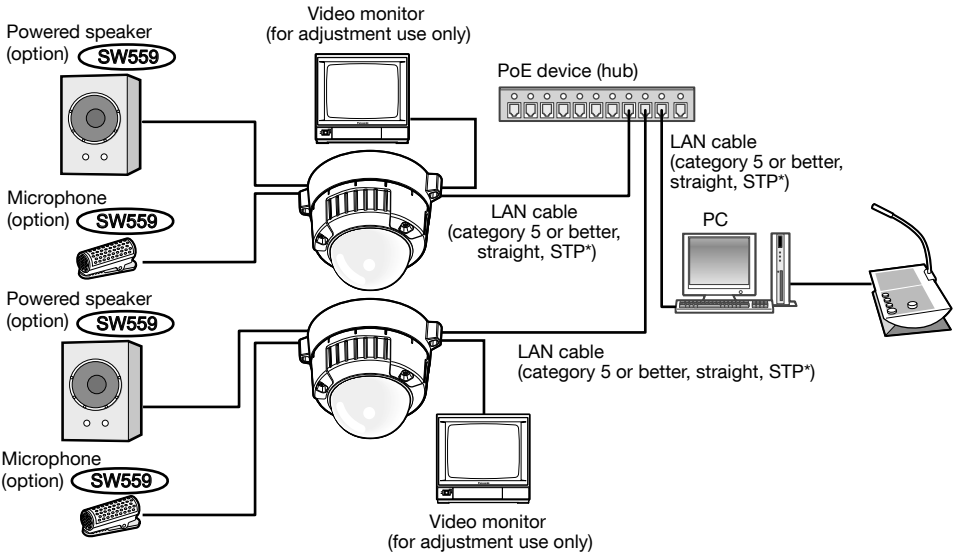

<Required cable>

LAN cable (category 5 or better, straight, STP*)

* For Europe

IMPORTANT:

- The video monitor is used for checking the adjustment of the angular field of view when installing the camera or when servicing. It is not provided for recording/monitoring use.
 - Use a switching hub or a router which is compliant with 10BASE-T/100BASE-TX.
 - Power supply is required for each network camera. When using a PoE device (hub), 12 V DC power supply is unnecessary.
-

Installation

1 Mount the camera.

<Using a two-gang junction box>

- ① Connect each cable. (☞ Page 24) Waterproof the connecting portion. (☞ Page 27)
- ② Align the "OPEN" on the camera with the projection of the camera attachment (accessory).
- ③ Engage the camera attachment fixing screws on the rear of the camera in the camera mounting holes of the camera attachment (accessory) and rotate the camera in the arrow direction to secure the camera attachment (accessory) and camera.

Rotate the camera until a click is heard so that the projection of the camera attachment (accessory) will be set to the "LOCK" position.

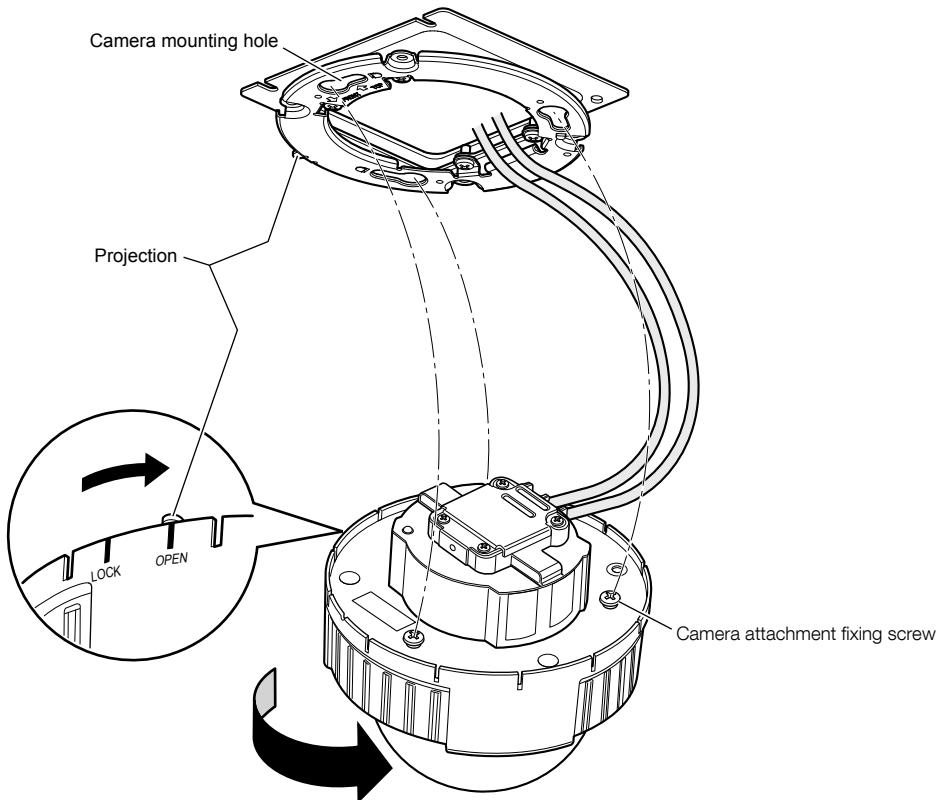

<Using the mount bracket>

- ① Attach the camera onto the camera attachment (accessory) while aligning the "OPEN" mark of the camera with the projection of the camera attachment (accessory).

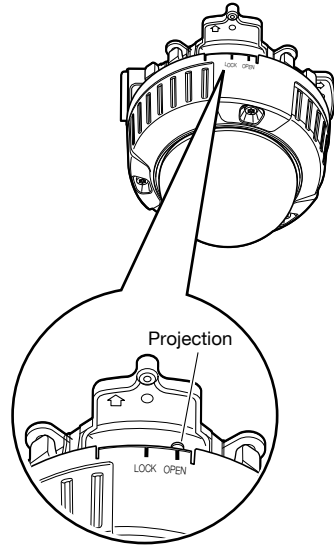
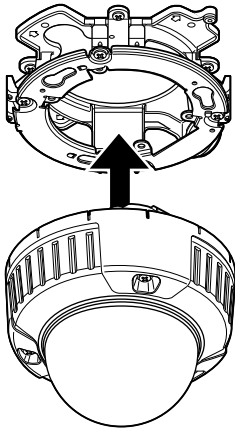

IMPORTANT:

- When mounting the camera body, cables shall be run between the camera attachment (accessory) and mount bracket as indicated by the arrows in the illustration.
- * Cable running as indicated by the arrows in the illustration is an example. Cable running shall be varied with installation environment.

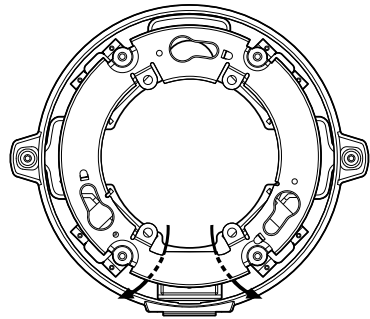

- ② Engage the camera attachment fixing screws of the camera with the screw hole of the camera attachment (accessory) and rotate the camera in the direction of the arrow to secure the camera to the camera attachment (accessory). Rotate the camera until a click is heard so that the projection of the camera attachment (accessory) will be set to the "LOCK" position.

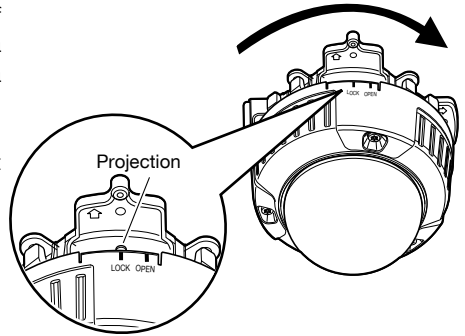

- ③ Connect the cables on the side of the mount bracket. (☞ Page 24)
Waterproof the connecting portion. (☞ Page 27)

IMPORTANT:

- Disconnect the 12 V power source and PoE power source to prevent power from being supplied during mounting work.
-

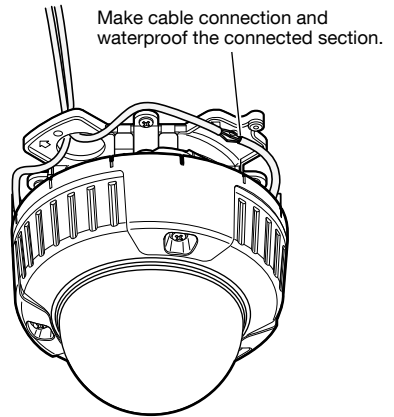

- ④ Accommodate the connected cables inside the cable guide of the camera mount bracket.

IMPORTANT:

- To prevent the cables from being caught when the base cover (accessory) is attached, keep the cables inside the cable guide.
-

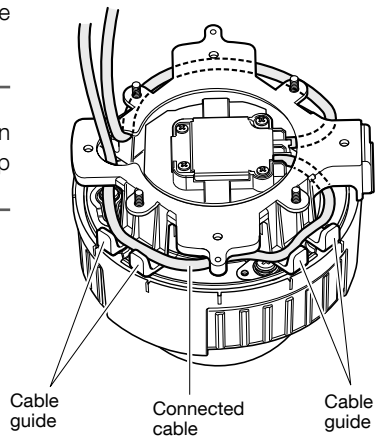

- ⑤ Attach the base cover (accessory) that was removed according the steps in page 19.

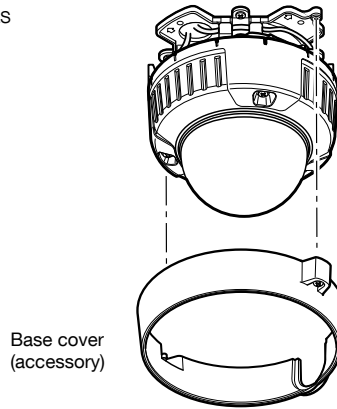

- ⑥ Use the bit for tamperproof screw (accessory) to tighten the fixing screws provided on both sides of the base cover (accessory). (Recommended tightening torque: 0.78 N·m {0.58 lbf·ft})

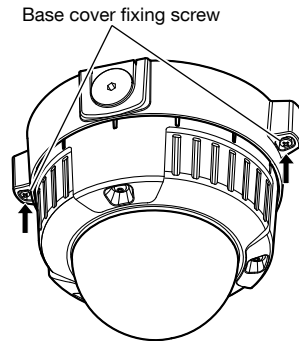

2 Detach the enclosure from the main body by loosening the three fixing screws.

Loosen the three fixing screws by using the bit for tamperproof screw (accessory).

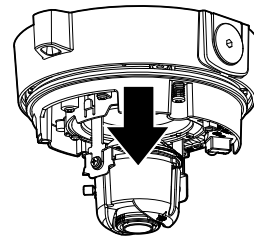

IMPORTANT:

- Do not hold the inner dome when carrying the camera. Otherwise, the camera part may fall and it may damage the camera.
- Because the inner dome is non-detachable, do not detach it when installing this product.
- Remove the cover film from the transparent part of the dome cover after the installation is complete. Do not touch the dome cover by hand directly after removing the cover film.

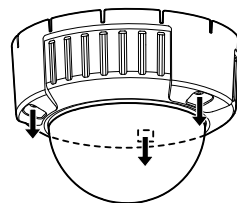

- 3** Secure the camera to the mount bracket with the camera fixing screw (red, 1 position).
The illustration is an example of using the mount bracket (accessory).

IMPORTANT:

- Be sure to tighten the camera fixing screw. Failure to observe this may cause camera trouble due to water leakage or camera falling.
(Recommended tightening torque: 0.78 N·m {0.58 lbf·ft})
-

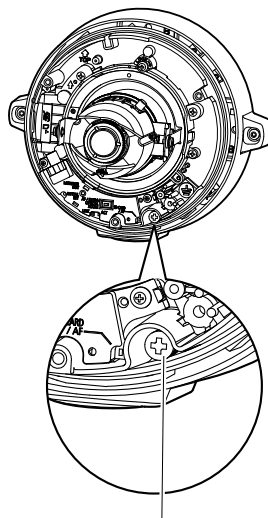

Camera fixing screw (red)
* The camera fixing screw shall be securely tightened.

- 4** Connect the RCA pin cable to the monitor output connector (see page 16) for adjustment (only for adjustment of the angle field of view).

IMPORTANT:

- The monitor output connector is provided only for checking the adjustment the angle field of view on the video monitor when installing the camera or when servicing. It is not provided for recording/ monitoring use.
 - Black bands may appear at the top, bottom, right and left of the screen. (There is no problem with adjustment since the angle field of view is not affected.)
 - The video output on the monitor for adjustment does not guarantee the video performance or image quality.
-

Adjustment

1 Adjust the camera angle.

When determining the camera angle, repeat fine adjustments by gradually moving the panning table, tilting table, and azimuth adjustment ring.

Horizontal position (Panning)

Loosen the panning lock screw, rotate the panning table to adjust the pan direction. (Adjustable range: 340 °)

Panning is possible within the range of 180 ° (when panning clockwise) and 160 ° (when panning counterclockwise).

After adjustment, tighten the panning lock screw to fix the panning table.

(Recommended tightening torque: 0.59 N·m {0.44 lbf·ft})

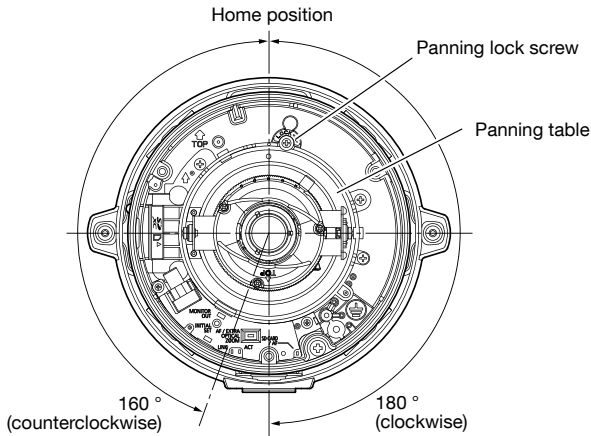

Vertical position (Tilting)

Loosen the tilting lock screws (x2), and rotate the tilting table to adjust the tilting direction. (Adjustable range: $\pm 75^\circ$) Since a variable focal lens is used, it is possible to change the angular field of view. This lens can also be rotated in the reverse direction, but the image azimuth is reversed. In this case, the image azimuth can be modified when the panning table is rotated to the direction of clockwise panning (180 °).

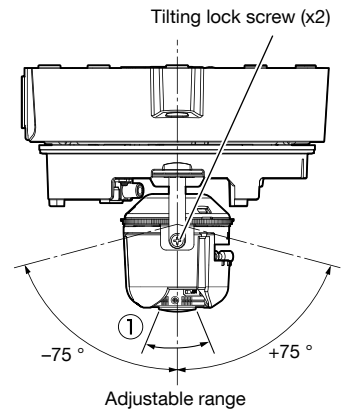

<Lens angular field of view (① Angle)>

Horizontal: 24.20° (TELE) to 86.60° (WIDE)

After adjustment, tighten the tilting lock screws (x2) to fix the tilting table.
(Recommended tightening torque: 0.59 N·m {0.44 lbf·ft})

Note:

- When the tilting table is turned to the edge of the adjustable range ($\pm 75^\circ$), it must be noted that the shadow of the enclosure may be projected.
 - When the camera is installed to a wall, the image is reversed in the default settings. To correct the way the image is displayed, rotate the panning table 180° clockwise, or select "On" for "Upside-down" from the setup menu. For information about performing the "Upside-down" setting from the setup menu, refer to the Operating Instructions (included in the CD-ROM).
-

Image tilt adjustment

Rotate the azimuth adjustment ring to adjust the azimuth angle of the image. (Adjustable range: $\pm 100^\circ$)

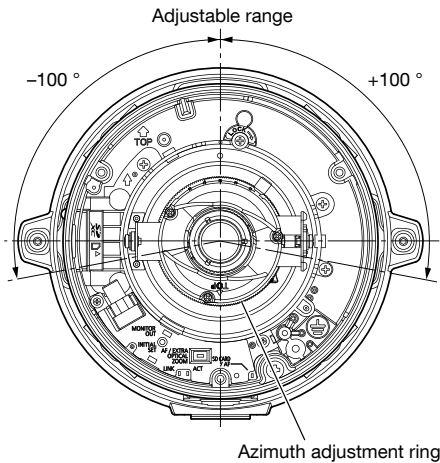

2 Adjust the angular field of view and the focus.

Adjust the angular field of view in accordance with the distance between the camera lens and a photographic subject. These adjustments shall be performed together with the camera angle adjustment.

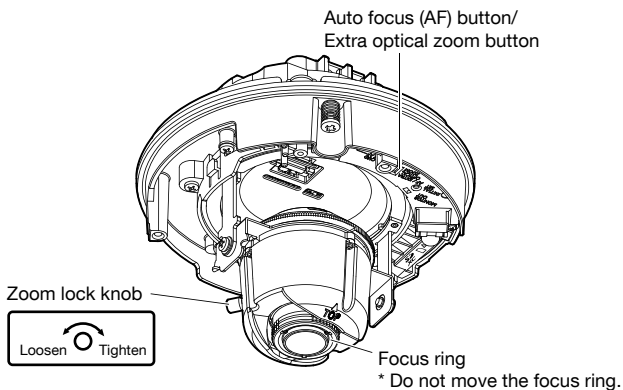

- ① Loosen the zoom lock knob and move the knob between TELE and WIDE to obtain the appropriate angle of view.
- ② Press the auto focus (AF) button twice quickly to perform basic adjustments. The lamp blinks during auto focus (AF) adjusting. When the adjustment is completed, adjust the viewing angle while watching the screen.

Note:

- The focus may not be adjusted appropriately when the zoom lock knob is positioned at the "W" (or "T") end. In this case, adjust the focus again by slightly turning the zoom lock knob to the direction of "T" (or "W").
 - With basic adjustments, the focus can be adjusted quickly. For more accurate adjustments use the detailed adjustments.
-

- ③ To adjust the angular field of view with a higher zooming effect even after turning the zoom lock knob almost fully in the "T" direction, hold down the auto focus (AF) button/extra optical zoom button for 5 seconds or more. 2x extra optical zoom will be applied. When the image capture size under "VGA" is applied, the zoom factor can be adjusted up to 2x without deterioration of image quality. When holding down the auto focus (AF) button/extra optical zoom button again for 5 seconds or more, 1x extra optical zoom will be applied.
- ④ Tighten the zoom lock knob.
- ⑤ After fixing the viewing angle, press the auto focus (AF) button once. The auto focus lamp lights for about 10 seconds, and a detailed adjustment for the focus is automatically performed.

IMPORTANT:

- Do not move the focus ring.
 - Defocus may be caused by the reinstalled enclosure. In this case, perform the auto focus function from the setup menu.
 - After performing basic adjustments, make sure to press the auto focus (AF) button once to perform detailed adjustments.
-

Note:

- If the zoom lock knob is fully turned in the "W" direction, the periphery may become dark. In such a case, turn the zoom lock knob in the "T" direction for readjustment.
 - If the zoom lock knob is slightly tightened before the zoom is adjusted, the knob will become stable, making fine adjustments easier to perform.
 - When shooting in the following place or the following subjects, focus may not be adjusted automatically. In this case, adjust the focus manually from the setup menu. Refer to the Operating Instructions (included in the CD-ROM) for how to perform the manual focus adjustment from the setup menu.
 - Subj. moving frequently
 - Subj. with large illuminance change
 - Subj. with low illuminance
 - Subj. with reflection or extra brightness
 - Subj. through a window
 - Place where the dome cover easily becomes dirty
 - Subj. with less contrast such as white wall
 - Subj. with heavy flicker
 - If the 2x extra optical zoom is applied when "2048×1536", "1920×1080", "1280×960", "1280×720" is selected for the image capture size, the image quality will be deteriorated because the effect of Extra Optical Zoom is not provided.
 - When images in the near-infrared light area change from color to black & white, out-of-focus may be occurred according to the nature of optical property. In this case, the focus can automatically be corrected by selecting "Auto" or "Preset" for "Adjusting method" on the setup menu (The focus will not automatically be adjusted according to the illumination level change once the focus is corrected.) Refer to the Operating Instructions (included in the CD-ROM) for how to set "Adjusting method" on the setup menu.
-

- 3** Attach the enclosure to the camera.
Attach the cutout part of the main unit to the grooved part of the enclosure.

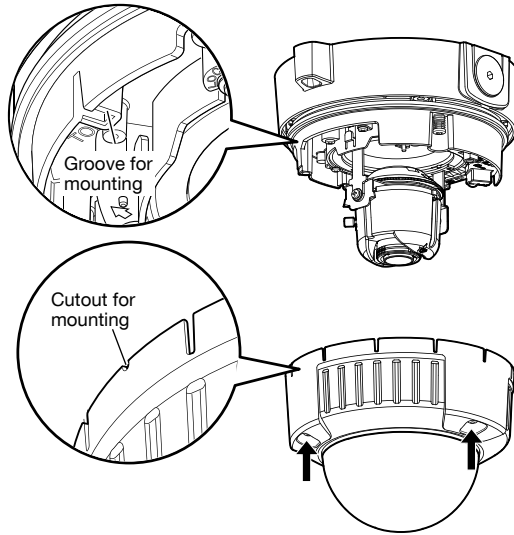

IMPORTANT:

- Securely tighten all the fixing screws (x3) of enclosure. Otherwise, water exposure may cause damage or malfunction of camera, or camera dropping may result in injury. (Recommended tightening torque: 0.78 N·m {0.58 lbf·ft})
 - Remove the protection sheet from the outside of the dome.
-

Configure the network settings

Configuring the camera so that it can be accessed from a PC

The following are descriptions for when the camera with default settings is configured. If you are using firewall software on your PC, the Setup Program may not be able to find any cameras on your network. Configure the setting of the camera after temporarily invalidating the firewall software. Contact the network administrator or your Internet service provider for information about configuring the settings of the network.

- 1 Insert the provided CD-ROM into the CD-ROM drive of your PC.
 - The License Agreement will be displayed. Read the Agreement and choose “I accept the term in the license agreement”, and click [OK].
 - The launcher window will be displayed. If the launcher window is not displayed, double click the “CDLauncher.exe” file on the CD-ROM.

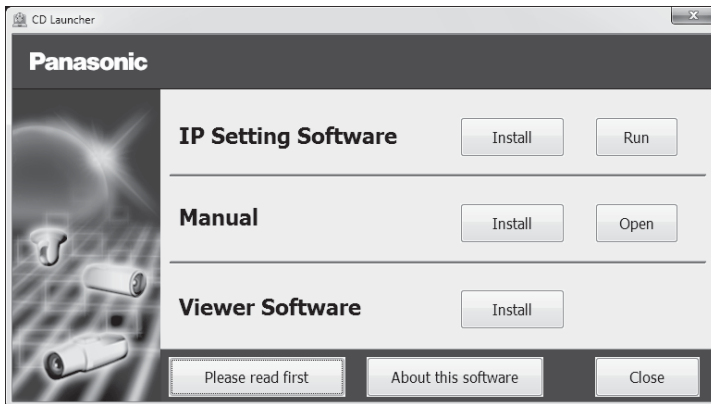

Note:

- Refer to “Using the CD-ROM” in the Operating Instructions on the provided CD-ROM for further information about CDLauncher.
-

- 2 Click the [Run] button next to [IP Setting Software].
[Panasonic IP Setting] screen will be displayed. Click the [Network Settings] button after selecting the MAC address/IP address of the camera to be configured.

- 3 Select the camera you want to configure, and click [Access Camera].

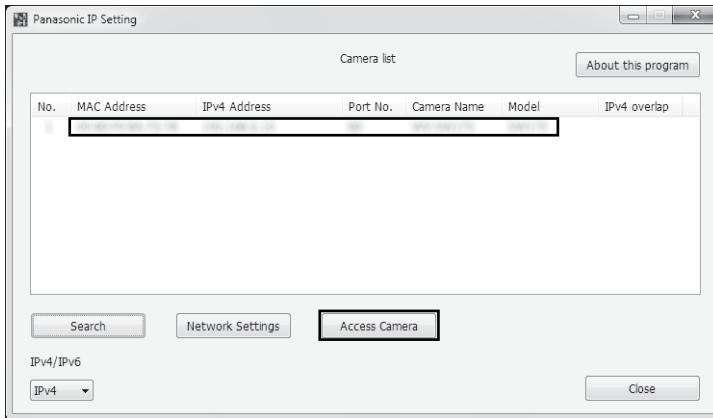

Note:

- When cameras are displayed in [Panasonic IP Setting] screen, click the camera with same MAC address as the MAC address printed on the camera that you want to configure.

- 4 If the installation screen of the viewer software “Network Camera View 4S” is displayed, follow the instructions of the wizard to start the installation. (The viewer software is installed from the camera.)
- The “Live” page will be displayed.
 - If you cannot install the viewer software “Network Camera View 4S” or if images are not displayed, click the [Install] button next to [Viewer Software] on the launcher window to install the software.
 - Perform the [Time & date] settings in the “Setup” - “Basic” page before using the camera.

Note:

- When no image is displayed on the “Live” page, refer to the Troubleshooting in the Operating Instructions on the provided CD-ROM.
- It is possible to enhance the network security by encrypting the access to cameras using the HTTPS function. Refer to the Operating instructions on the provided CD-ROM for how to configure the HTTPS settings.
- Click the [Setup] button on the “Live” page, the user authentication window will be displayed. Enter the default user name and password as follows, and log in.
User name: admin
Password: 12345
- When changing settings related to the network settings, such as connection mode, IP address, and subnet mask, click the [Network Settings] button in [IP Setting Software] screen as shown in step 3, then change each setting.
- Due to security enhancements in “IP Setting Software”, “Network settings” of the camera to be configured cannot be changed when around 20 minutes have passed after turning on the power of the camera. (When the effective period is set to “20 min” in the “Easy IP Setup accommodate period”.)
However, settings can be changed after 20 minutes for cameras in the initial set mode.
- “Network Camera Recorder with Viewer Software Lite” which supports live monitoring and recording images from multiple cameras is available. For further information, refer to our website (<http://security.panasonic.com/pss/security/support/info.html>).

Troubleshooting

Before asking for repairs, check the symptoms with the following table.

Contact your dealer if a problem cannot be solved even after checking and trying the solution in the table or a problem is not described below.

Symptom	Cause/solution	Reference pages
Power is not turned on.	<p>When using DC power supply</p> <ul style="list-style-type: none">• Is DC 12 V power supply connected to the 2P power supply cable? → Check whether the connection is appropriately established.• Is the AC adaptor in use compliant with the Specifications? → Check the Specifications regarding AC adaptor. <p>When using a PoE device for power supply</p> <ul style="list-style-type: none">• Are the PoE device and the network cable of the camera connected using a LAN cable? → Check whether the connection is appropriately established.• Depending on the PoE device, the power supply will stop when the demanded power exceeds its total power limit for all PoE ports. → Refer to the operating instructions of the PoE device in use.	24

Specifications

• Basic

Power source:	12 V DC, PoE (IEEE802.3af compliant)
Power consumption:	SW559 12 V DC: 850 mA, PoE 48 V: 180 mA (Class 0 devices) SW558 12 V DC: 830 mA, PoE 48 V: 175 mA (Class 0 devices) * ONLY CONNECT 12 V DC CLASS 2 POWER SUPPLY (UL 1310/CSA 223) or LIMITED POWER SOURCE (IEC/EN/UL/CSA 60950-1).
Ambient operating temperature:	-40 °C to +50 °C {-40 °F to 122 °F}* Ambient operating humidity: Less than 90 % (no condensation)
Waterproof:	Camera: IP66 (IEC60529) * Only when installation work specified in this book is properly performed and appropriate waterproof treatment is performed Compliant with 50 J (IEC 60068-2-75)/IK10 (IEC 62262)
Shock resistance:	
Monitor output (for adjusting the angular field of view):	VBS: 1.0 V [p-p]/75 Ω, composite signal, RCA jack
EXT I/O terminal cable:	SW559 ALARM IN1/ DAY/NIGHT IN, ALARM IN2/ ALARM OUT, ALARM IN3/ AUX OUT (x1 for each) SW558 ALARM IN, ALARM OUT, AUX OUT (x1 for each)
Microphone/line input cable SW559 :	∅3.5 mm monaural mini jack Input impedance: Approx. 2 kΩ
For microphone input:	Applicable microphone: Plug-in power type Supply voltage: 2.5 V ±0.5 V
For line input:	Input level: Approx. -10 dBV
Audio output cable SW559 :	∅3.5 mm stereo mini jack (monaural output) Output impedance: Approx. 600 Ω Line level
Dimensions:	∅164 mm x 146 mm (H) x 191.5 mm (W) {∅6-15/32 inches x 5-3/4 inches (H) x 7-17/32 inches (W)} (including projection of the base cover fixing screw)
Mass:	Approx. 1.6 kg {3.53 lbs}
Finish:	Main body: Aluminum die cast, light gray Dome section: Clear polycarbonate resin

* When using this product without turning the power off. (However, the temperature inside the camera shall be -10 °C {14 °F} or higher.) Perform settings or startup operations when the ambient temperature is -30 °C {-22 °F} or higher. The auto focus function is not available until the heater unit of the camera raises the internal temperature of the camera.

• Camera

Image sensor:	1/3-type MOS image sensor
Effective pixels:	Approx. 3.1 megapixels
Scanning area:	4.51 mm (H) × 3.38 mm (V) {3/16 inches (H) x 1/8 inches (V)}
Scanning system:	Progressive
Minimum illumination (SW559) :	Color: 0.5 lx {0.05 footcandle} (F1.3, Auto slow shutter: Off (1/30 s), Gain: On(High)) 0.03 lx {0.003 footcandle} (F1.3, Auto slow shutter: max. 16/30 s, Gain: On(High))* BW: 0.06 lx {0.006 footcandle} (F1.3, Auto slow shutter: Off (1/30 s), Gain: On(High)) 0.004 lx {0.0004 footcandle} (F1.3, Auto slow shutter: max. 16/30 s, Gain: On(High))*
Minimum illumination (SW558) :	Color: 0.5 lx {0.05 footcandle} (F1.3, Auto slow shutter: Off (1/30 s), Gain: On(High)) 0.03 lx {0.003 footcandle} (F1.3, Auto slow shutter: max. 16/30 s, Gain: On(High))* BW: 0.3 lx {0.03 footcandle} (F1.3, Auto slow shutter: Off (1/30 s), Gain: On(High)) 0.02 lx {0.002 footcandle} (F1.3, Auto slow shutter: max. 16/30 s, Gain: On(High))*
	* Converted value
Super-Dynamic:	On/Off
Dynamic range:	52 dB typ. (only at Super-Dynamic On)
Gain (AGC):	On(High)/ On(Mid)/ On(Low)/ Off
Adaptive black stretch:	On/Off (only at Super-Dynamic Off)
Light control mode setting:	Indoor scene (50 Hz/60 Hz)/ Outdoor scene/ Fix shutter
Shutter speed:	1/30, 3/100, 3/120, 2/100, 2/120, 1/100, 1/120, 1/250, 1/500, 1/1000, 1/2000, 1/4000, 1/10000 (only at Super-Dynamic Off)
Auto slow shutter:	Off (1/30 s), max. 2/30 s, max. 4/30 s, max. 6/30 s, max. 10/30 s, max. 16/30 s
Day & Night (IR) (SW559) :	On/ Off/ Auto1/ Auto2
Day & Night (electrical) (SW558) :	Off/Auto
White balance:	ATW1/ ATW2/ AWC
Digital noise reduction:	High/Low
Video analytics	
Face detection*1:	On/Off (with the XML notification setting)
Privacy zone:	Gray/Off (up to 2 zones available)
VIQS:	On/Off (up to 2 areas available)
Camera title on screen:	Up to 20 characters (alphanumeric characters, marks) On/Off
Video motion detection (VMD alarm):	On/Off, (up to 4 areas available)

*1 To use the "XML notification" and "Face detection" functions, you need to install the extension software.

• Lens

Zoom ratio:	3.6x Extra optical zoom: 10.8x (Imaging mode: 2 megapixel, under 640x360 resolution)
Focal length:	2.8 mm - 10 mm
Maximum aperture ratio:	1:1.3 (WIDE) - 1:3.0 (TELE)
Angular field of view:	■ Image capture mode: 2 mega pixel [16:9], 1.3 mega pixel [16:9] Horizontal: 24.20° (TELE) – 86.60° (WIDE) Vertical: 13.50° (TELE) – 47.57° (WIDE) ■ Image capture mode: 3 mega pixel [4:3] Horizontal: 25.56° (TELE) – 93.15° (WIDE) Vertical: 19.30° (TELE) – 68.49° (WIDE) ■ Image capture mode: 1.3 mega pixel [4:3] Horizontal: 20.18° (TELE) – 71.48° (WIDE) Vertical: 15.14° (TELE) – 53.19° (WIDE)
Adjusting angle:	Horizontal: 180 ° (clockwise), 160 ° (counterclockwise) Vertical: ±75 ° Image tilt adjustment range: ±100 °

• Network

Network:	10BASE-T/100BASE-TX, RJ45 connector
Resolution:	Imaging mode: 2 megapixel [16:9] H.264 1920x1080/ 640x360/ 320x180 max.30 fps JPEG(MJPEG) 1920x1080/ 640x360/ 320x180 max.30 fps
	Imaging mode: 1.3 megapixel [16:9] H.264 1280x720/ 640x360/ 320x180 max.30 fps JPEG(MJPEG) 1280x720/ 640x360/ 320x180 max.30 fps
	Imaging mode: 1.3 megapixel [4:3] H.264 1280x960/ VGA(640x480)/ QVGA(320x240) max.30 fps JPEG(MJPEG) 1280x960/ VGA(640x480)/ QVGA(320x240) max.30 fps
Image compression method*1:	Imaging mode: 3 megapixel [4:3] H.264 1280x960/ max.15 fps JPEG(MJPEG) 2048x1536/ max.15 fps H.264 Image quality: Low/ Normal/ Fine Transmission type: Unicast/Multicast Bit rate: Constant bit rate/Best effort: 64 kbps/ 128 kbps/ 256 kbps/ 384 kbps/ 512 kbps/ 768 kbps/ 1024 kbps/ 1536 kbps/ 2048 kbps/ 3072 kbps/ 4096 kbps/ 6144 kbps/ 8192 kbps/ 10240 kbps/ 12288 kbps/ 14336 kbps Frame rate: 1 fps/ 3 fps/ 5 fps/ 7.5 fps/ 10 fps/ 12 fps/ 15 fps/ 20 fps/ 30 fps JPEG (MJPEG) Image quality: 0 SUPER FINE/ 1 FINE/ 2/ 3/ 4/ 5 NORMAL/ 6/ 7/ 8/ 9 LOW (10 steps: 0-9) Transmission type: PULL/PUSH
Transmission interval:	0.1 fps - 30 fps (JPEG frame rate will be restricted when displaying both JPEG and H.264 images.)

Transmission the image cut out:	2 megapixel [16:9] H.264 640x360/ 320x180 max.30 fps MJPEG 640x360/ 320x180 max.30 fps
	<hr/>
	1.3 megapixel [16:9] H.264 640x360/ 320x180 max.30 fps MJPEG 640x360/ 320x180 max.30 fps
	<hr/>
	1.3 megapixel [4:3] H.264 VGA(640x480)/ QVGA(320x240) max.30 fps MJPEG VGA(640x480)/ QVGA(320x240) max.30 fps
Audio compression method	SW559 : G.726 (ADPCM) 32 kbps/16 kbps G.711 64 kbps
Bandwidth control:	Unlimited/ 64 kbps/ 128 kbps/ 256 kbps/ 384 kbps/ 512 kbps/ 768 kbps/ 1024 kbps/ 2048 kbps/ 4096 kbps/ 8192 kbps
Protocol:	IPv6: TCP/IP, UDP/IP, HTTP, HTTPS, RTP, FTP, SMTP, DNS, NTP, SNMP, DHCPv6, MLD, ICMP, ARP IPv4: TCP/IP, UDP/IP, HTTP, HTTPS, RTSP, RTP, RTP/RTCP, FTP, SMTP, DHCP, DNS, DDNS, NTP, SNMP, UPnP, IGMP, ICMP, ARP
OS*2 *3:	Microsoft Windows 7 Microsoft Windows Vista Microsoft Windows XP SP3
Browser:	Windows Internet Explorer 9.0 (32-bit) Windows Internet Explorer 8.0 (32-bit) Windows Internet Explorer 7.0 (32-bit) Microsoft Internet Explorer 6.0 SP3
Maximum concurrent access number:	14 (Depends on network conditions)
FTP client:	Alarm image transmission, FTP periodic transmission (When the FTP transmission is failed, backup on an optional SD memory card is available. SW559)
Multi-screen:	Up to 16 camera images can be displayed simultaneously on a multi-screen. (Including the camera itself)
Compatible SDXC/SDHC/ SD memory card (option)	SW559 : Manufactured by Panasonic (SD speed class 4 or higher) SDXC memory card: 64 GB SDHC memory card: 4 GB, 8 GB, 16 GB, 32 GB SD memory card: 2 GB (except miniSD card and microSD card)
Cellular phone compatibility:	JPEG image, AUX control (by access level)
Mobile terminal compatibility: (As of October, 2013)*4	iPad, iPhone, iPod touch (iOS 4.2.1 or later) Android™ mobile terminals

*1 Transmission for 2 streams can be individually set to transmission.

*2 For further information about PC system requirements and precautions for when using Microsoft Windows 7, Microsoft Windows Vista, or Windows Internet Explorer, click "Manual" - "Open" from the supplied CD-ROM and refer to "Notes on Windows® / Internet Explorer® versions".

*3 When using IPv6 for communication, use Microsoft Windows 7 or Microsoft Windows Vista.

*4 For further information about compatible devices, refer to our website
(<http://security.panasonic.com/pss/security/support/info.html>).

Standard accessories

Installation Guide (this document)	1 set
Warranty card	1 set
CD-ROM*1	1 pc.
Code label*2	1 pc.

The following parts are used during installation procedures.

4P alarm cable	1 pc.
Camera attachment	1 pc.
2P power cable	1 pc.
Fixing screws (M4 x 8 mm)	5 pcs. (of them, 1 for spare)
Base cover	1 pc.
Mount bracket	1 pc.
Bit for tamperproof screw	1 pc.
Waterproof tape	1 pc.
PAL setting tool	1 pc.

*1 The CD-ROM contains the operating instructions and different kinds of tool software programs.

*2 This label may be required for network management. The network administrator shall retain the code label.

Optional accessories

Ceiling mount bracket	WV-Q169 or WV-Q169/V*1
Smoke Dome Cover	WV-CW4S or WV-CW4SA*2
User License Accessory (For H.264)	BB-HCA8A BB-HCA8CE

*1 WV-Q169/V and WV-Q169 are the same, even though the model numbers are different.

*2 WV-CW4SA and WV-CW4S are the same, even though the model numbers are different.

Information for Users on Collection and Disposal of Old Equipment and used Batteries



These symbols on the products, packaging, and/or accompanying documents mean that used electrical and electronic products and batteries should not be mixed with general household waste.

For proper treatment, recovery and recycling of old products and used batteries, please take them to applicable collection points, in accordance with your national legislation and the Directives 2002/96/EC and 2006/66/EC.

By disposing of these products and batteries correctly, you will help to save valuable resources and prevent any potential negative effects on human health and the environment which could otherwise arise from inappropriate waste handling.

For more information about collection and recycling of old products and batteries, please contact your local municipality, your waste disposal service or the point of sale where you purchased the items.

Penalties may be applicable for incorrect disposal of this waste, in accordance with national legislation.



For business users in the European Union

If you wish to discard electrical and electronic equipment, please contact your dealer or supplier for further information.

[Information on Disposal in other Countries outside the European Union]

These symbols are only valid in the European Union. If you wish to discard these items, please contact your local authorities or dealer and ask for the correct method of disposal.



Cd

Note for the battery symbol (bottom two symbol examples):

This symbol might be used in combination with a chemical symbol. In this case it complies with the requirement set by the Directive for the chemical involved.

For U.S. and Canada:

Panasonic System Communications Company of North America, Unit of Panasonic Corporation of North America

www.panasonic.com/business/
For customer support, call 1.800.528.6747
Two Riverfront Plaza, Newark, NJ 07102-5490

Panasonic Canada Inc.

5770 Ambler Drive, Mississauga,
Ontario, L4W 2T3 Canada
(905)624-5010
www.panasonic.ca

For Europe and other countries:

Panasonic Corporation

<http://panasonic.net>

Panasonic System Networks Co., Ltd.
Fukuoka, Japan

Authorised Representative in EU:

Panasonic Testing Centre
Panasonic Marketing Europe GmbH
Winsbergring 15, 22525 Hamburg, Germany

